



OWNER'S MANUAL

Ver.2.00



WARNING

- For safety reasons, please read the manual first before plugging in machine.
- Please keep this manual properly for convenient reference as needed.

About This Manual

Thank you for purchasing this product.

The manual describes how to install, set up, use and maintain the product. The main purpose of the manual is to instruct how to operate the product correctly and safely. Please follow all the safety and warning instructions in the manual to avoid personal injury and product damage.

This product may only be maintained by a technician. A technician mainly refers to a person who has obtained a certificate of senior middle school related to mechanical engineering, electrical engineering or at a level equal to that of technical senior middle school graduates, and is engaged routinely in the maintenance, management, repair of amusement machine.

Please keep this manual properly for easy reference as needed. Moreover, if the operator entrust another party to operate, move, transport, install, maintain and repair the machine, please read relevant content and instruct concerned party to observe all the instructions and precautions in this manual regarding the particular action to be taken.

When transferring the ownership of this product, be sure to provide this manual with the machine.

For further information about the game and repair (including consumables), please contact our company.

© 2013 GuangZhou Wahlap Technology Limited All Rights Reserved

Unauthorized reproduction of this document or any of its contents in any form is strictly forbidden.

Table of Contents

About This Manual

1. Safety Precautions	1
1.1 Magnitudes of Risk	1
1.2 Placing Site	1
1.3 Operation Precautions	2
1.4 Precaution during Play	3
1.5 Transporting and Moving	3
1.6 Installing and Placing	4
1.7 Caution & Warning Stickers	5
2. Product Introduction	6
2.1 Product Specification	6
2.2 Overview	7
2.3 Spare Parts	8
2.4 Shipment List	9
2.5 Packing List	11
2.6 Installation instructions	12
2.7 Warranty	13
3. Game Description	14
3.1 Appearance Design	14
3.2 Game Introduction	14
3.3 How to Play	14
3.4 Instructions of Multiplayer	15
4. Instructions of Testing and Setup	16
4.1 IO Testing	17
4.1.1 Light Testing	17
4.1.2 Sound Channel Testing	18
4.1.3 Coin Selector Testing	18
4.1.4 Button Testing	19
4.2 Game Parameter Setup	19
4.3 Operation Control Parameter Setup	20
4.4 Revenue Log	20
4.5 Restore Factory Settings	21
4.6 RESUME	21
5. Maintenance and Servicing	22
5.1 Care and Maintenance	22
5.2 Spare Parts Replacement	23
5.2.1 Replacement of Light Box LED	23
5.2.2 Replacement of Light Box Binocular LED	24

5.2.3	Replacement of Light Box Brake LED.	25
5.2.4	Replacement of LED inside Milky White Tube	25
5.2.5	Replacement of Exhaust Pipe LED Panel.	26
5.2.6	Replacement of Rear LED	27
5.2.7	Replacement of Coin Selector	27
6.	Assembly Drawing	29
6.1	Assembly Tree Drawing.	29
6.2	General Assembly Drawing.	30
6.3	Seat Frame Component.	31
6.3.1	Seat Base Component	32
6.3.2	Swing Component.	33
6.3.3	Body Plastic Component	34
6.3.4	Handle Component.	35
6.3.5	Handle Plastic Component.	36
6.4	Upper and Lower Wooden Frame Component	37
6.4.1	Main Wooden Frame Component	38
6.4.2	Testing Service Board Component	39
6.4.3	Wooden Frame Woofer Component	40
6.4.4	Host Component	41
6.4.5	IO board Component.	42
6.4.6	Coin Door Component.	43
6.4.7	Power Switch Component	44
6.5	Controller Plastic Component	45
6.6	Light Box Component.	46
6.6.1	Lamp Cap Component	47
6.6.2	Iron Light Box Component	48
6.6.3	Left Light Box Component	49
6.7	Liquid Crystal Rear Door Component.	50
6.8	Main Wooden Frame Rear Door Component	51
6.9	Display Framework Component.	52
7.	Sketch Map of Printed Pattern	53
8.	General Wiring Diagram	54
9.	After-Sales Service.	57

1. Safety Precautions

1.1 Warning Stickers

In order to avoid injury to related people and damage to property, please observe the followings:

PLEASE READ FIRST

- The following marks can be used to indicate the magnitudes of risk and damage caused by ignorance or improper operation:



means “may result in serious injury or death”



means “may result in minor injury or property damage”

Serious Injury: refers to the situations in which hospital treatment or long-term treatment will be accepted because of losing sight, getting hurt, getting burnt, electric shock, fracture or intoxication.

Minor Injury: refers to the cases that there is no need to go to hospital or accept long-term treatment.

Property Damage: refers to the damage of house, facility, or hurt of livestock and pet

1.2 Placing Site

Warning

- This machine is designed for indoor use only. Never install the machine outdoors. Meanwhile, please avoid the following locations indoor:
 - Direct sunlight, water leakage, damp and high temperature places.
 - Near Flammable, volatile, or/and dangerous substance.
 - Slope, unstable places or locations subject to frequent vibration.
 - Near emergency exit, fire extinguisher or similar equipment.
- The rear part has the vent for heat emission from PC or screen. Don't place anything nearby to avoid game failure.
- Provide a space of minimum 30cm between the rear of the machine and the wall for good ventilation and heat emission

1.3 Safety Precautions

The owner shall pay attention to the followings when placing, checking and repairing machine to insure player's security and avoid damage:

Warning

- Make sure to plug the game into 110V or 220V main outlet to avoid fire and electric shock.
- Make sure to turn off the power when performing maintenance and service to avoid electric shock or short circuit.
- Do not unplug or plug the plug instantly.
- Don't touch the power plug with a wet hand to avoid electric shock.
- Don't expose the power cord/grounding line on the passageway. Failure to do this will damage the power cord, causing electric shock or short circuit.
- Don't lay anything near the power cord to avoid fire.
- Do not pull the power cord when unplugging, please hold the plug to avoid power cord damage, causing fire or electric shock.
- In case of power cord damage, please contact the local distributor for replacement
- Only use fuse and spare parts specified by our company
- Connect the connector firmly and tighten the screws.
- Do not dismount, replace or convert the product without our permission in order to avoid damage and human injury due to improper operation.
- Check and maintain the machine regularly.
- Keep "Warning stickers" clean and legible. Replace it immediately when the words are not legible or the dirt can't be removed.
- Please contact our service center when performing any work that is not described in this manual, and follow the instruction provided.

1.4 Precautions during Play

Caution

- In order to avoid injury and accident during play, the following people shall not play the game:
 - People who are injured or less mobile.
 - Person with poor health condition, such as hypertension or heart disease.
 - Person wearing high-heeled or slippery shoes.
 - Person who can't touch the pedal.
 - Pregnant woman, drunk people.
- When a player feels uncomfortable during play, remind the person to have a break, or stop playing.
- Make sure the player reads the warning labels and other indications, and plays in accordance with the instructions to avoid accidents such as electric shock and short circuit.
- Bystander shall not operate any button when the player is playing the game to avoid unnecessary trouble.

1.5 Transporting and Moving

Caution

Transporting

- When transporting the machine with an elevator, be sure to employ "Lift Point" to prevent accident and damage to the machine.
- To prevent movement when transporting the machine on a vehicle, please fix the casters and fully retract the adjusters. Failure to do this may cause damage to the machine.
- When carrying the machine with a forklift, be sure to insert the fork to fork position and lift stably. If not, it may cause accident and damage to the machine.
- The glass and LCD screen are fragile. Avoid violent vibration or shock when transporting.

Moving

- Before moving the machine, unplug the power plug to prevent accident. Don't damage the cord.
- Pay attention to the obstructions and uneven surface when moving the machine to prevent accident and damage to the machine.
- Fully retract all adjusters before moving to prevent accident and hazard.
- Make sure to use at least two persons to conduct the above work to avoid accident and injury
- Pay attention to the moving direction, see fig.



1.6 Installing and Placing

Pay attention to the following when placing the machine.

Caution

- Place the machine on the flat and slip resistant area.
- Use the adjusters to fix the machine (See diagram 1)
 1. Loosen the nuts for the adjusters (clockwise), tighten the bolts with a wrench (clockwise).
 2. Tighten the nut firmly (counter clockwise) and fix it well.

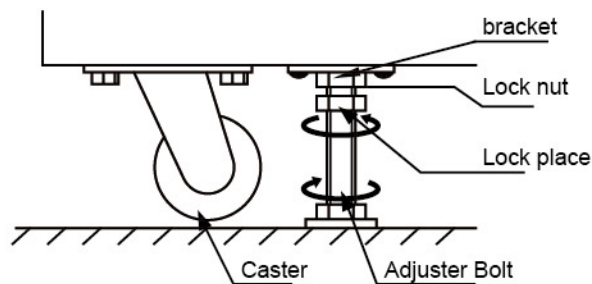

Diagram (1)

- Provide a space of minimum 30cm between the rear of the machine and the wall for good ventilation and heat emission (See diagram 2).

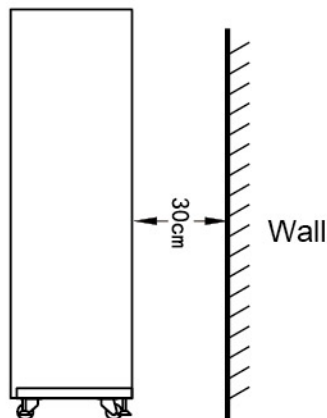
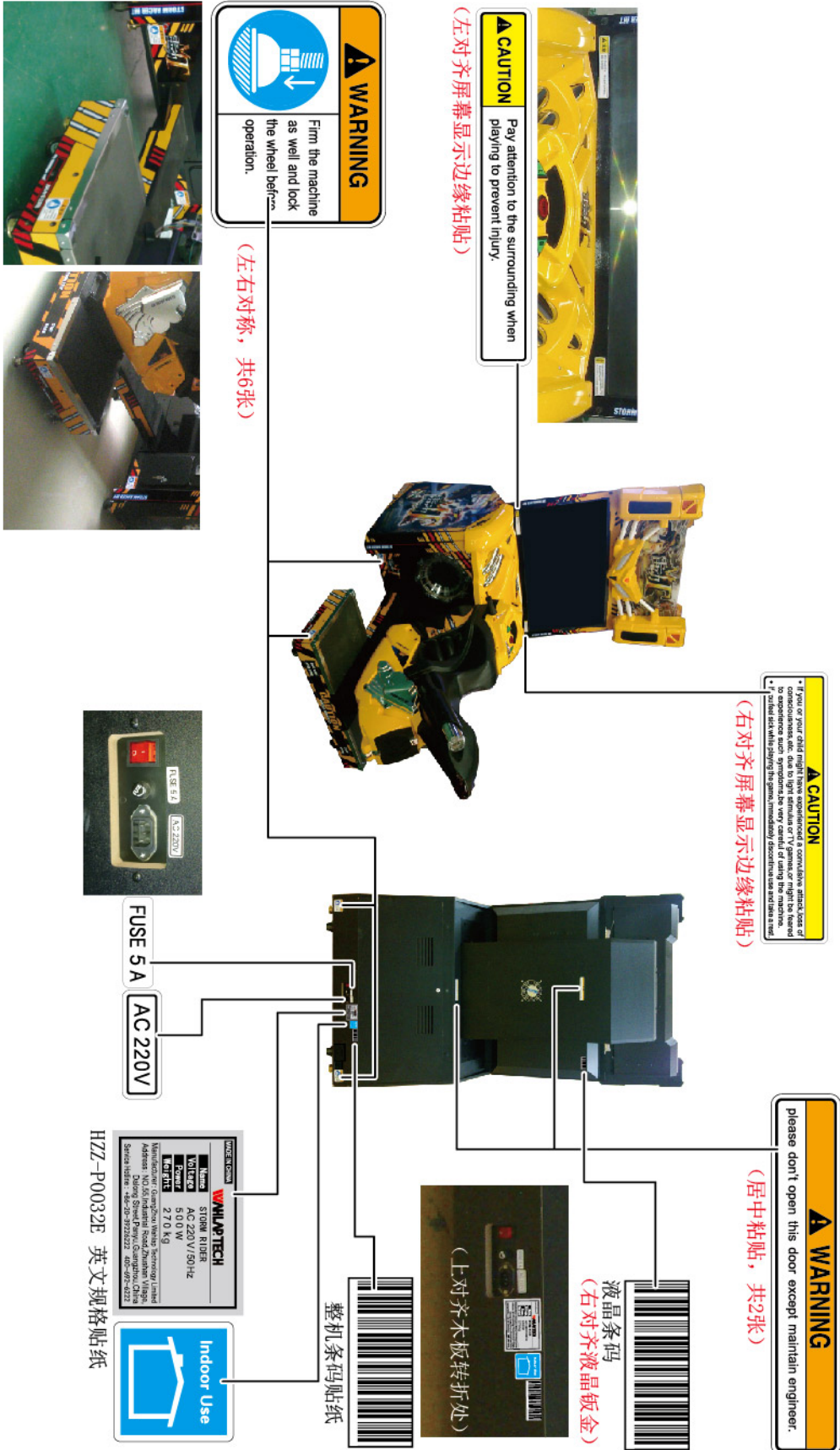

Diagram (2)

1.7 Caution & Warning Stickers



2. Product Description

2.1 Product Specification

■ Location	Indoor Only
■ Dimension	1108(W)X2189(D)X2034(H)
■ Rated Voltage	220V
■ Frequency	50Hz
■ Power Consumption	500W
■ Weight	270kg
■ Temperature Range	5~40 °C

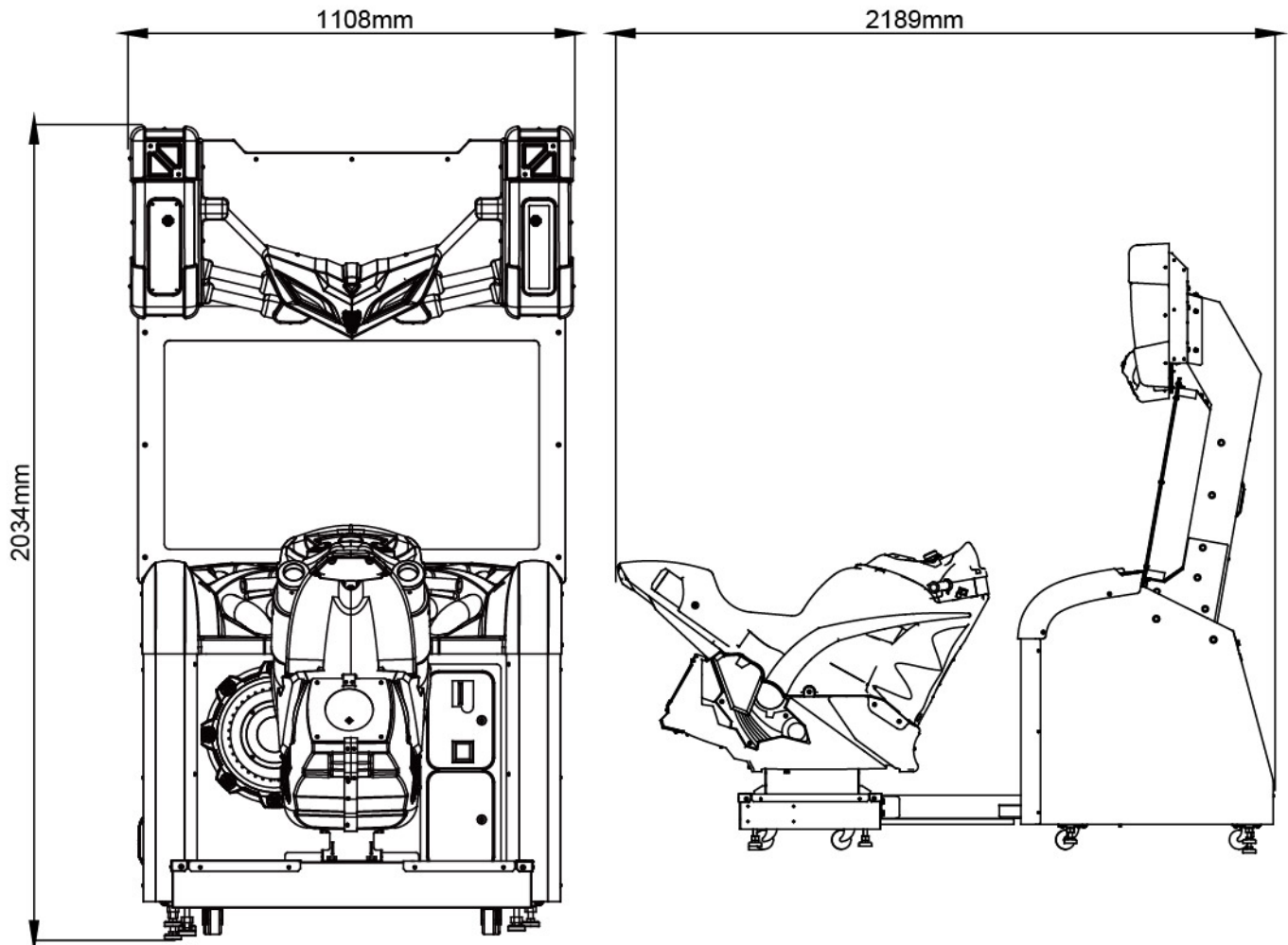

■ Front View

■ Side View

2.2 Overview

■ Side View

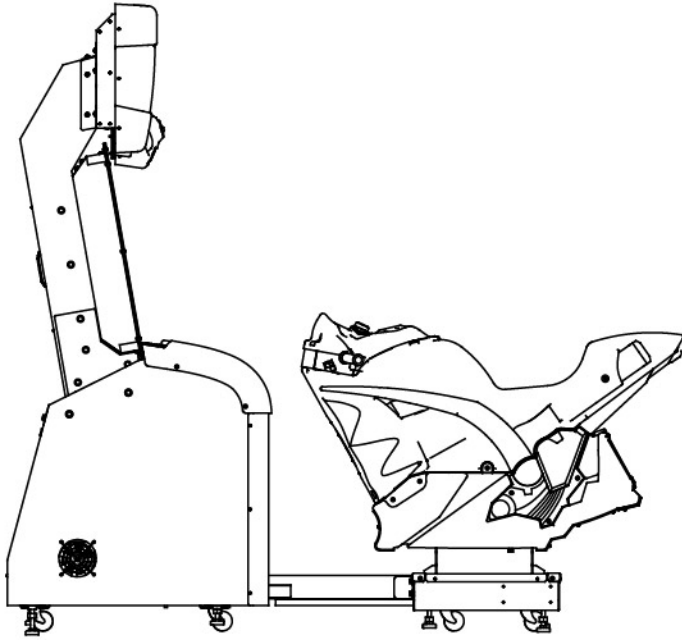

■ Rear View

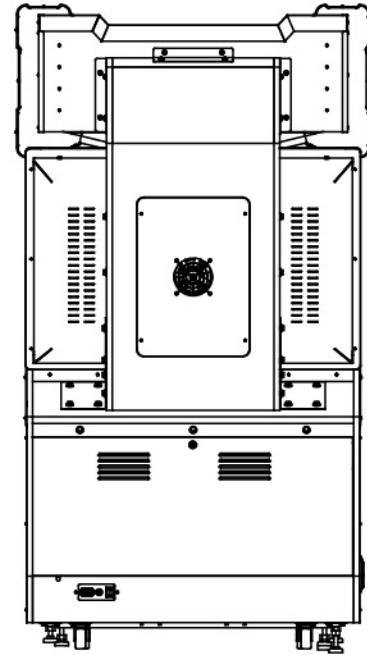

■ Top View

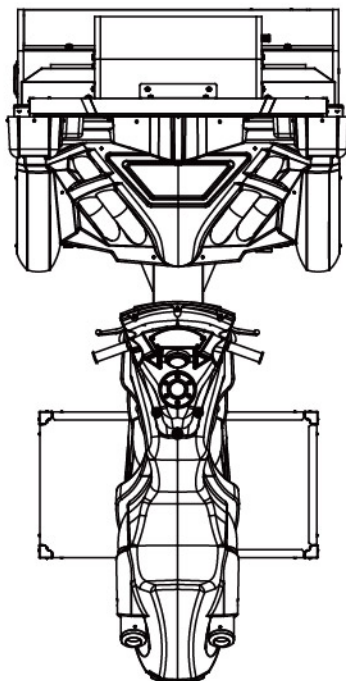

■ Bottom View

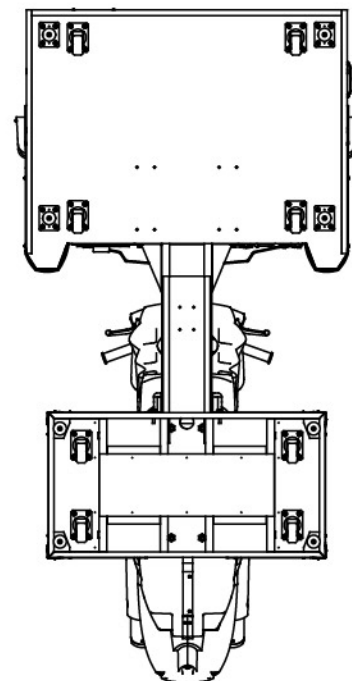

2.3 Spare Parts



2.4 Shipment List

■ Packing Carton 1

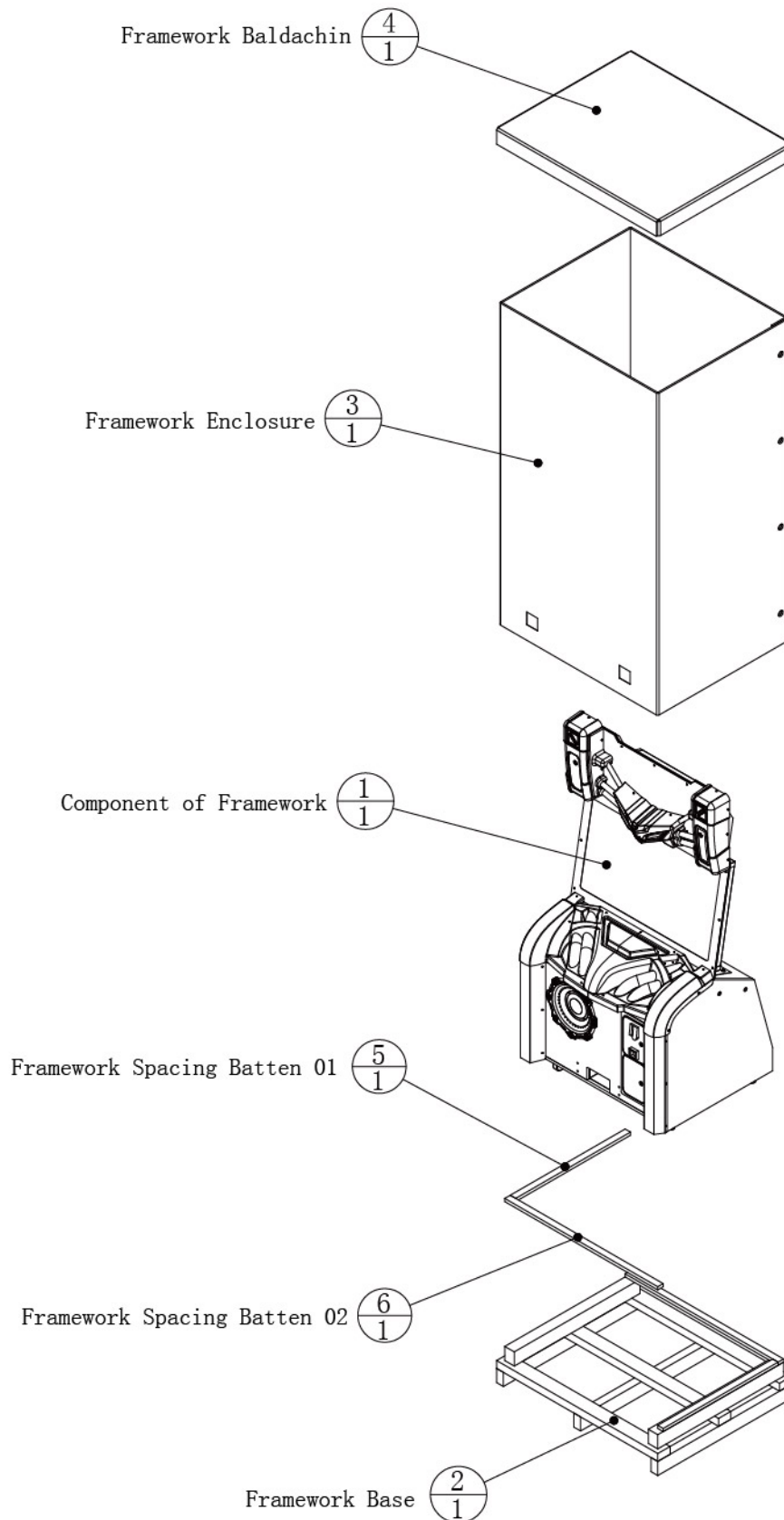

产品名称	雷动 MT
箱体重量	245 kg
箱体尺寸 (W) (D) (H)	1195 x 995 x 2200 mm
箱体备注	主箱体组件
C/NO.	1/2

■ Packaging Carton II

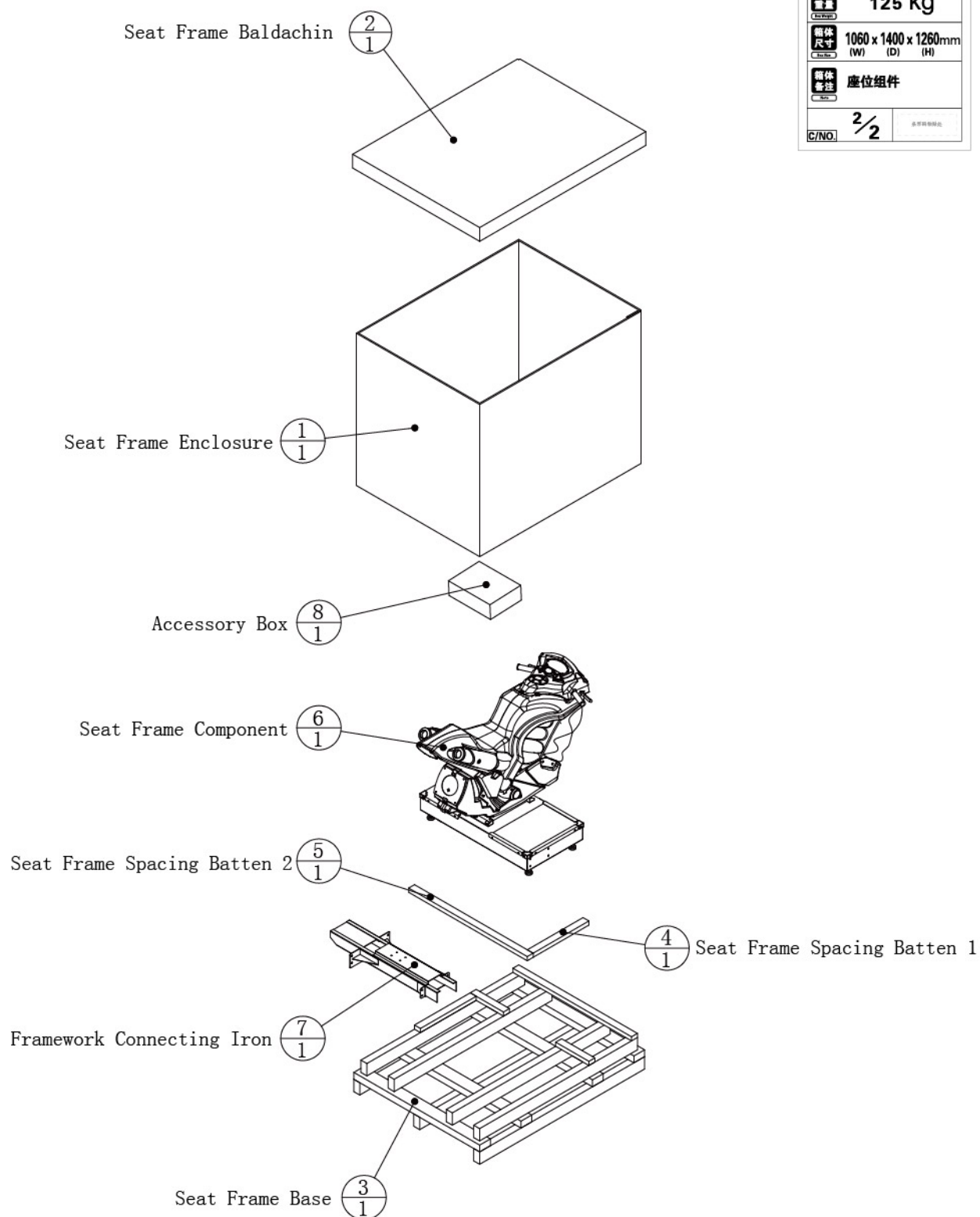

2.5 Packing List

Please check the following items after purchasing our product. If any part missing or damaged, please contact our sales person!

Description	Specification	Quantity	Remarks
Power Wire (two plug, three interpolation)	3m (1.0mm ²) 250V	1	
Key of Same Number	5555锁匙	2	
Key of Miscellaneous Number	M7-S	2	
Flat Gasket	φ 8* φ 22*2.0 (镀黑)	8	
Spring Washer	M8 (镀黑)	8	
Hexagonal Screw	M8*40 (镀黑)	8	
Network Cable	5M	1	
Instruction Manual		1	

2.6 Installation Instructions

■ First Step

1. Move the mounts horizontally towards the display framework to align the mounts with all interfaces of display framework. Then fasten both sides with flat gasket, spring washer and M8*40 hexagonal screw.

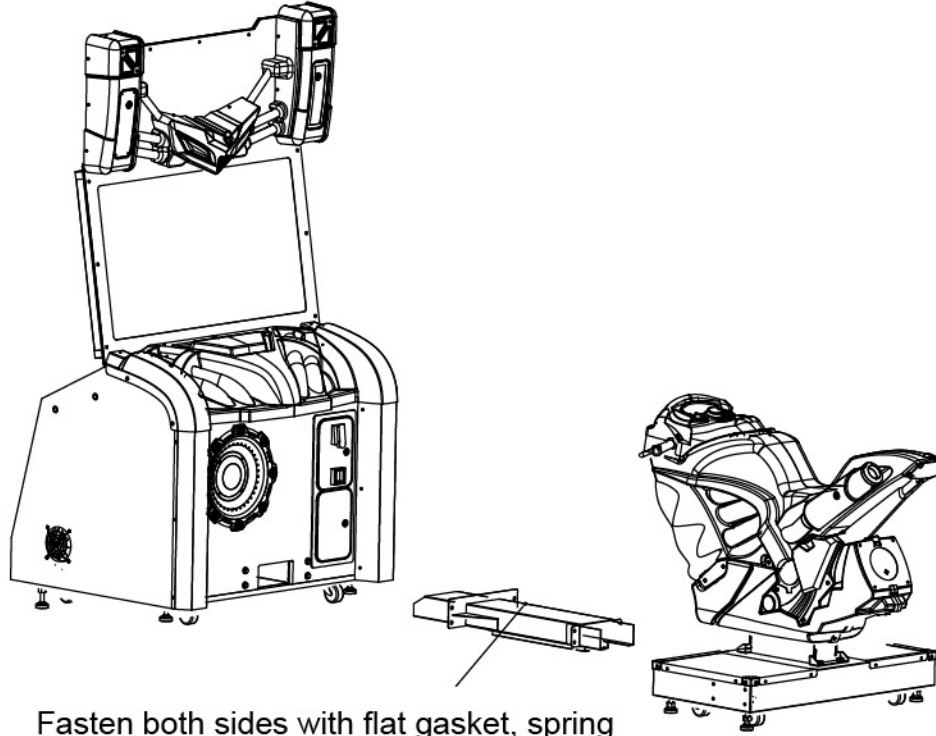

Fasten both sides with flat gasket, spring washer and M8*40 hexagonal screw.

2.7 Warranty

■ Scope

- Inquiry regarding product can be assisted for free.
- The warranty scope for consumables and durables may differ from product to product. Please contact our after-sales service center for detailed information. The right of final interpretation is reserved.

■ Exclusive

- Damage caused by force majeure such as god will.
- Failure caused by carelessness, such as water contact, falling down, toppling, knocking.
- Failure caused by disobeying the instructions in this manual.
- Failure caused by operating the machine on inappropriate site.
- Change the original design and configuration for the game without notice.
- Failure to perform regular service and clean.
- Failure to fix the product in line with the manual's requirement.
- Malfunction or part damage caused by electromagnetic interference other electronic equipments generated.

■ Non-warranty Consumables

- Light tube and bulb
- Button lamp and switch
- Fragile items
- Solenoid
- Other spare parts

3. Game Description

3.1 Appearance Design

The main color design of Storm Racer MT is black and orange. The simulation driving framework design will make players feel like riding a real motorcycle. With streamlined design of overall appearance and brilliant lighting effect, you will feel more exciting and stimulating to experience the extreme motorcycle world. At the vehicle rear end is designed with loudspeakers. The appropriate angle of speakers has made the sound field effect better, which will effectively attract the onlooking players.

3.2 Game introduction

Storm Racer MT is a game independently researched and developed by Wahlap. It is a racing simulation game themed with extreme motorcycle racing. There are 11 racing tracks and high-definition real-time rendering 3D scene for this game. Players can choose all kinds of motorcycles to compete with rivals in all distinctive tracks to experience the fun of extreme stunt racing. Via LAN, the game supports multiplayer mode for player to compete with other players. There are following main features:

1. Simulation driving framework provides player with operating device and sense of feeling close to those of real motorcycle. Acceleration button is specially added and placed on the left front of motorcycle seat, which is convenient for player to accelerate while steering the turning direction, thus improving the sense of speed and raciness of game.
2. The real physical simulation of vehicle control. Players can twist the motorcycle accelerator simulation controller to control its move and then shake their bodies left and right to control the turning direction. Different control characteristics will be displayed according to different vehicle setting.
3. High definition resolution scene and advanced 3D rendering technology have truly described the splendid appearance of superbike. Together with the stereo speakers carried in front of seat and woofer inside the seat, they are all devoted to giving the highest audio-visual enjoyment to players to feel like at the scene.

3.3 How to play

1. As long as players feed enough game tokens and press the Start button on the head of seat, they can enter into the game selection screen; Players can press the Left and Right button on the head of seat to choose racing track and motorcycle model (all are confirmed by pressing Start button)
2. After selecting racing track and motorcycle model, press the Start button again to start the game. Players can twist the motorcycle accelerator simulation controller by right hand to control the movement of motorcycle and swing their bodies left and right to control the turning direction.
3. When the vehicle is moving, players can accelerate the vehicle by pressing the Acceleration button on the left handle to improve the sense of speed and raciness of game. Different control characteristics will be displayed according to different vehicle setting.
4. The game supports 2 to 4 persons VS network. Players can enter into the VS screen by selecting VS mode to enjoy the fun of multiplayer racing. The operation method is the same as above.

3.4 Instruction of Multiplayer

Networking Configuration Description

1 gigabit router with over 4 ports(the client shall purchase additionally) and 10 meters gigabit network cable (each machine is equipped with 1 randomly) are needed for VS network

On-line Setting of Machines

1. Respectively connect the network cable into each PC on-line socket.
2. Connect another side of each network cable to the router.
3. Arrange the cable through the groove behind the machine cabinet.
4. Reset all machines simultaneously to check whether or not the connection is successful. If not, make sure the connection of on-line cable is proper and fastened. As indicated below:

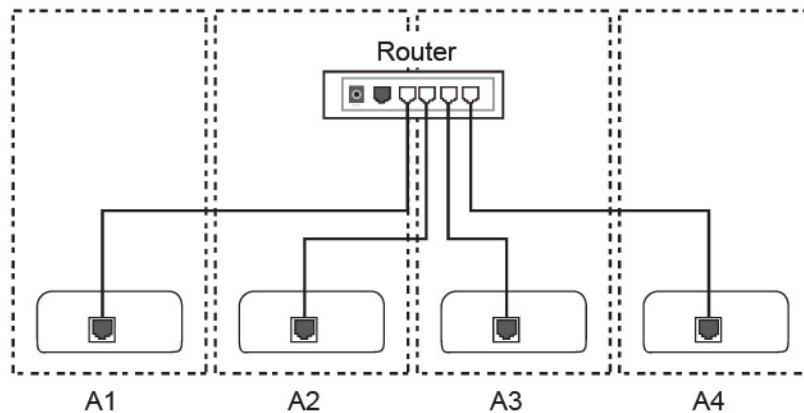

! ATTENTION

- Pay attention to protect the external wiring of machine from being trampled. If necessary, use tube to project the cable. If there are other cables near the machine, please mark the cables of machine to avoid causing the confusion. No mark or number has been made to the connecting cable. Keep the on-line cable away from heat source, humidity or electricity, such as neon light, compressor motor and transformer, etc.

4. Test and Setting

Administrator Main Menu

Find out the service button board installed on the top of inner cashbox of coin door.

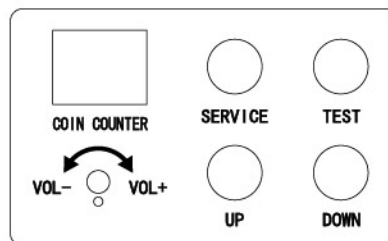

After entering the game interface, long press the “Testing” button on the service button board to enter the main menu interface of administrator.

On the administrator interface, press the “Testing” button to confirm, “Up” button to move up and “Down” button to move down.



4.1 IO Testing

On the administrator menu interface, select “I/O Testing” option to enter into the IO testing interface. On the IO testing menu, press Testing button to confirm, Up button to move up and Down button to move down.

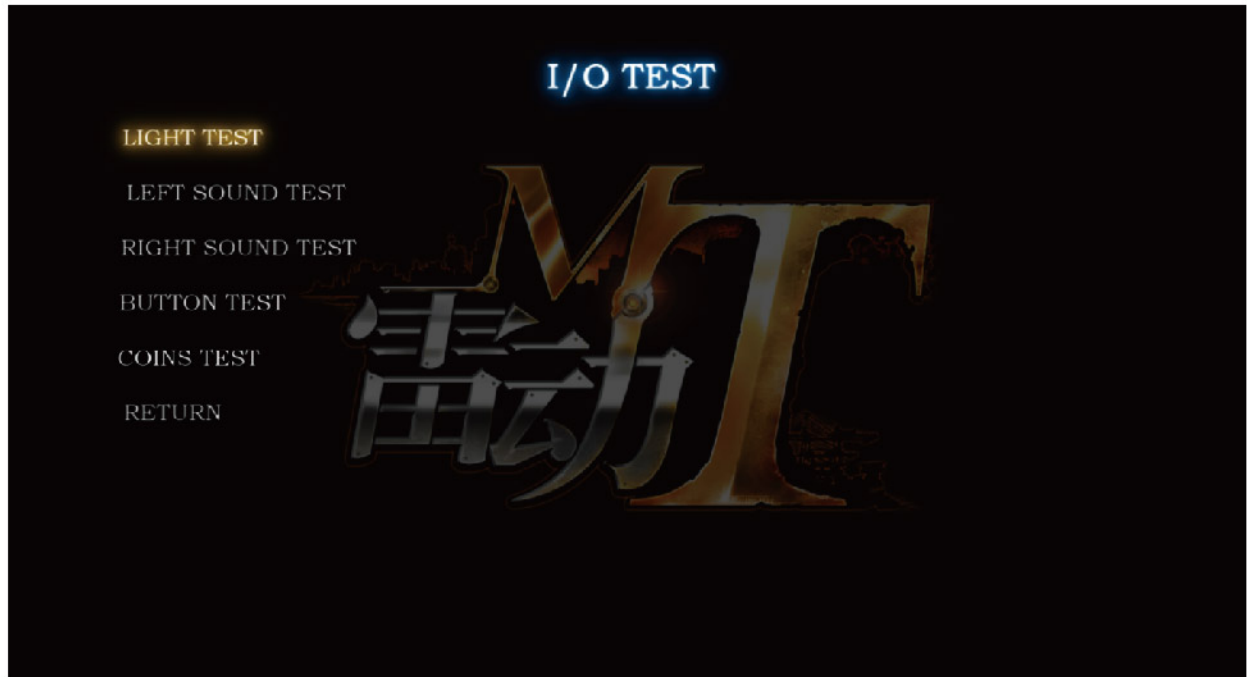

4.1.1 Light Testing

Select the “Light Testing” option under the IO testing menu
Light Testing Option -->All lamps on the machine light;



4.1.2 Sound Channel Testing

Select Left Channel Testing option under the IO testing menu,
Left Channel Testing option -->Play a sound once on the left channel
Right Channel Testing option -->Play a sound once on the right channel

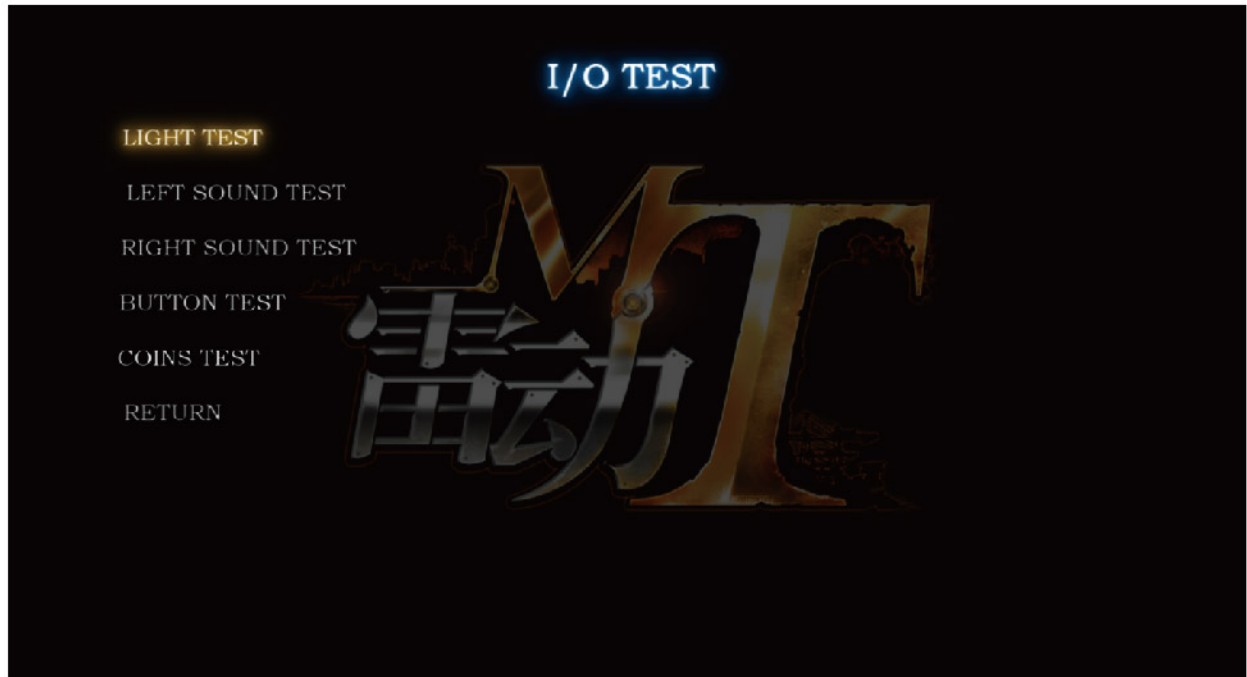

4.1.3 Coin Selector Testing

Select Coin Selector Testing option under IO testing menu to enter into the coin selector testing interface and the number of coins in the current slot will be displayed.
Press the Testing Button on the service button board under this interface to back to IO testing menu.



4.1.4 Button Testing

Under IO testing menu, select Button Testing option to enter into button testing interface. Then press the button on the machine, the corresponding part on the screen will be highlighted. On this interface, press Testing button on the service button panel to back to IO testing menu.

Back option -->Back to main menu of administrator



4.2 Game Parameter Setup

On the administrator menu interface, select Game Parameter Setup option to enter into the game parameter setup interface. On the game parameter setup interface, press Testing button to activate corresponding option. When the option was activated, press Up and Down button to adjust the numeric value and press Testing button to confirm after completion.



*LAP SETTING: Setting the lap numbers for the race. Default value is +0, can be set from -1 to +3.

*WINNER BONUS: Setting if there will be a bonus games for the winner while in multiplayer mode. Default value is NO.

Notice: While change the LAP SETTING, Please make sure all the machine that link to the same router was set to the same number.

4.3 Operation Control Parameter Setup

On the administrator menu interface, select Operation Control Parameter Setup option to enter into operation control parameter setup interface. Set up the control parameter according to the highlighted option and press Testing button to confirm after finishing each step before moving on to the parameter setup of next option. Press Testing button to back to main menu interface after finishing all setups.

In this interface will clear the control parameters you have set. In order to ensure normal operation of the game, be sure to set the parameters in accordance with the cues.

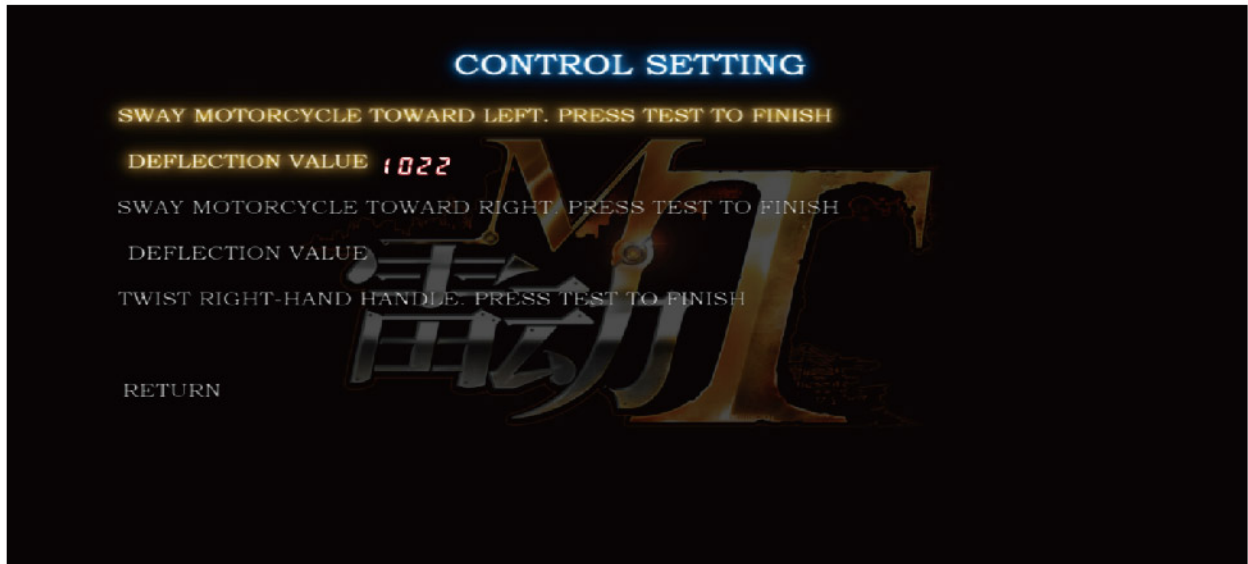

4.4 Revenue Log

On the administrator menu interface, select “Revenue Log” option to enter into revenue log interface. Select relevant option to read the revenue log.

Daily Revenue Record-->View the revenue record in the past ten days.

Monthly Revenue Record-->View revenue record base on month.

Total Revenue Record--> View total revenue record.



4.5 Restore Factory Settings

Restore factory settings-->Restore the factory default Settings.
This operation will clear the revenue record, and reset the game parameters and control parameters you have set.

4.6 RESUME

RESUME--> Resetgames

5. Maintenance and Servicing

5.1 Care and Maintenance

Even though the machine works normally for a long time, the fault will occur. Therefore, please perform routine check and maintenance concerning the following to ensure a long-term use.

■ External Inspection

- Stick “Warning” stickers correctly, keep it legible.
- Firmly tighten the bolt for each adjuster.
- Tighten screws for speaker assembly.
- Tighten the signboard firmly.
- Check if the screws fixing the parts loose.
- Check if the connectors loose or missing.

■ Operation Inspection (With power on)

- Sound is normally emitted from the speakers or not.
- Fluorescent lamps and button lamps light up or not
- Coin acceptor works properly or not.
- Lifting and falling devices work properly or not.
- YZ sensor works properly or not.

After completing all the checks, operate the game again and check the above items with full care!

■ Servicing (conducted by a technician only)

- Cut off the main power supply to avoid injury or electric shock when performing maintenance.
- Please contact our service center when performing any work that is not specified in this Manual, and follow the instruction provided by the service center.
- For consumables and spare parts (including screws), please use products specified by Wahlap Technology.
- Even though the main power is cut off, there is still high temperature and high pressure in the power board and the monitor. The person will be burnt or get an electric shock if he touches such parts. Please pay full attention to avoid contact.
- Be sure to cut off the main power when you alter a spare part or unplug a connector.

5.2 Spare Parts Replacement

5.2.1 Replacement of Light Box LED

1. Turn on 5 cross screws with cross screwdriver, unplug connecting terminal and remove the cover board on the left side to replace the LED lamp pasted on the left cover board (same as right side);
2. Turn on 8 cross screws with cross screwdriver, unplug connecting terminal and then withdraw the LED lamp within 4 light boxes to replace with the new one.

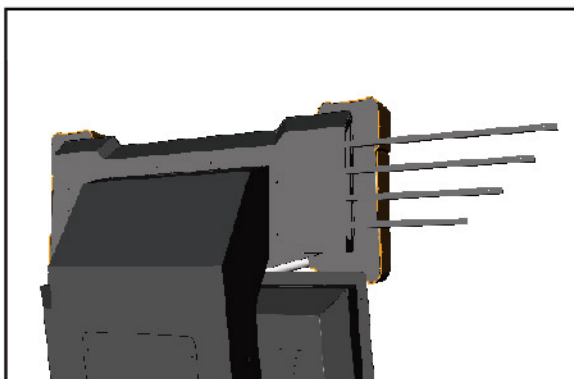
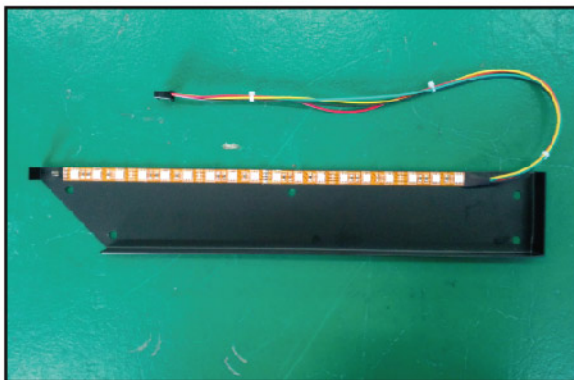
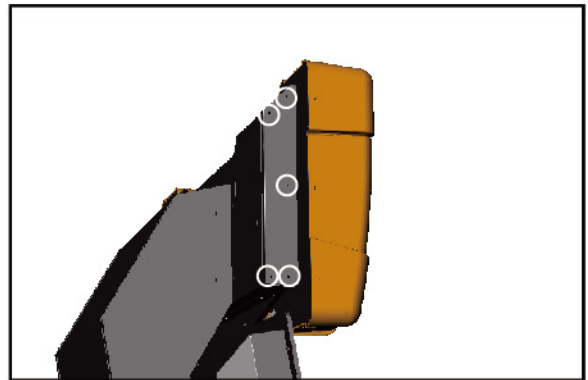

5.2.2 Replacement of Light Box Binocularus LED

1. Turn on 4 cross screws with cross screwdriver to remove the eyeshade on the head;
2. Turn on 4 cross screws with cross screwdriver and unplug connecting terminal to take down the LED lamp panel.



5.2.3 Replacement of Light Box Brake LED

1. Turn on 7 cross screws with cross screwdriver to remove the brake light box cover;
2. Turn on 2 cross screws with cross screwdriver and unplug connecting terminal to take down the LED lamp panel.

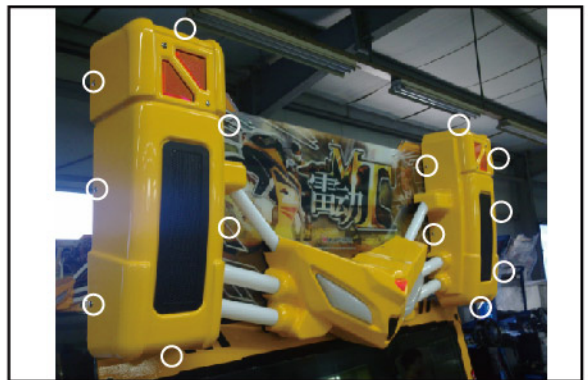

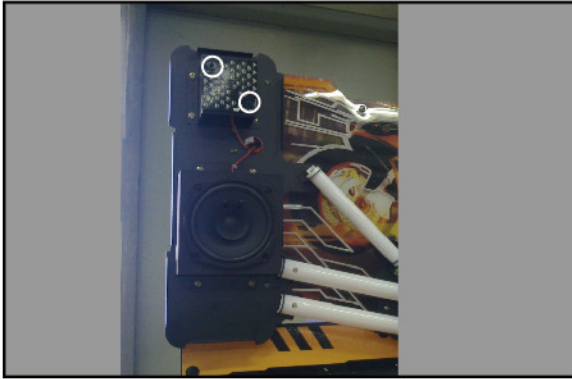

5.2.4 Replacement of LED inside Milky White Tube

1. First turn on 4 cross screws with cross screwdriver and take down the eyeshade on the head;
2. Then turn on 7 cross screws with cross screwdriver to remove the brake light box cover.
3. Turn on the cross screw at both ends of tube with cross screwdriver again to unplug connecting terminal and withdraw the LED lamp.



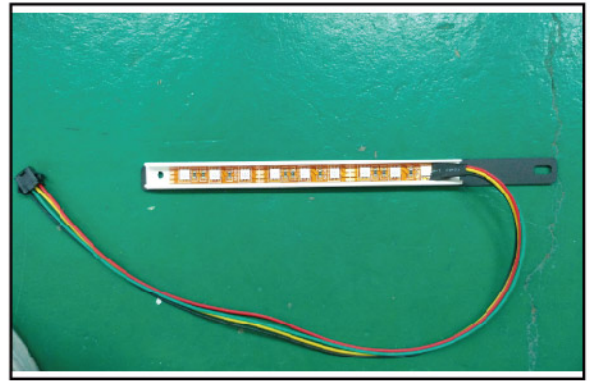

5.2.5 Replacement of Exhaust Pipe LED Lamp Panel

1. First turn on 2 cross screws with cross screwdriver to unplug injection molding and LED lamp panel;
2. Unplug connecting terminal;
3. Turn on 2 cross screws with cross screwdriver to replace the LED lamp panel.

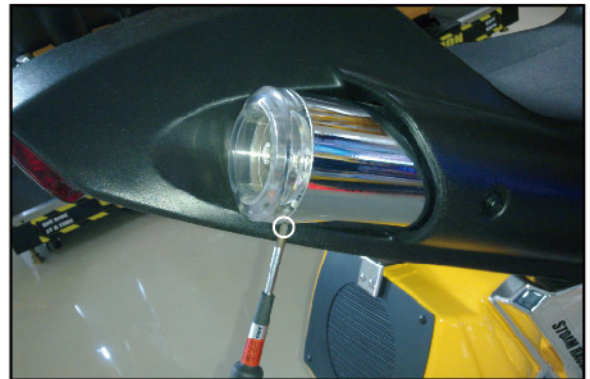

5.2.6 Replacement of Rear LED

1. Turn on 5 cross screws with cross screwdriver to remove the red lamp mask.
2. Turn on 2 cross screws with cross screwdriver and unplug connecting terminal to take down the LED lamp panel.

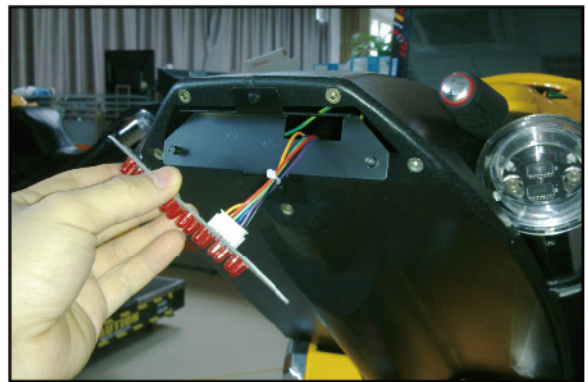

5.2.7 Replacement of Coin Selector

1. Open the door of cashbox by key;



2. Turn on 2 cross screws with cross screwdriver and 1 slotted crew with slotted screwdriver to remove the cover of coin selector;
3. Unplug connecting terminal and take down the coin selector.

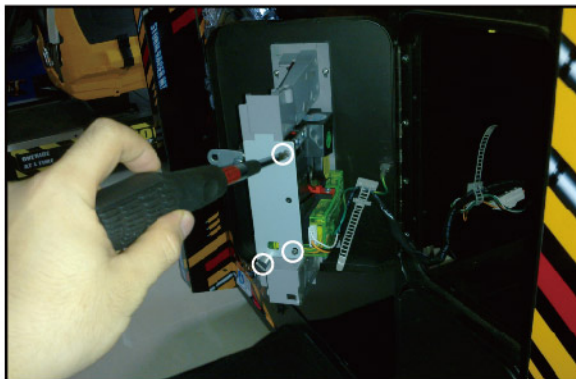

6. Assembly Drawing

6.1 Assembly Tree Drawing

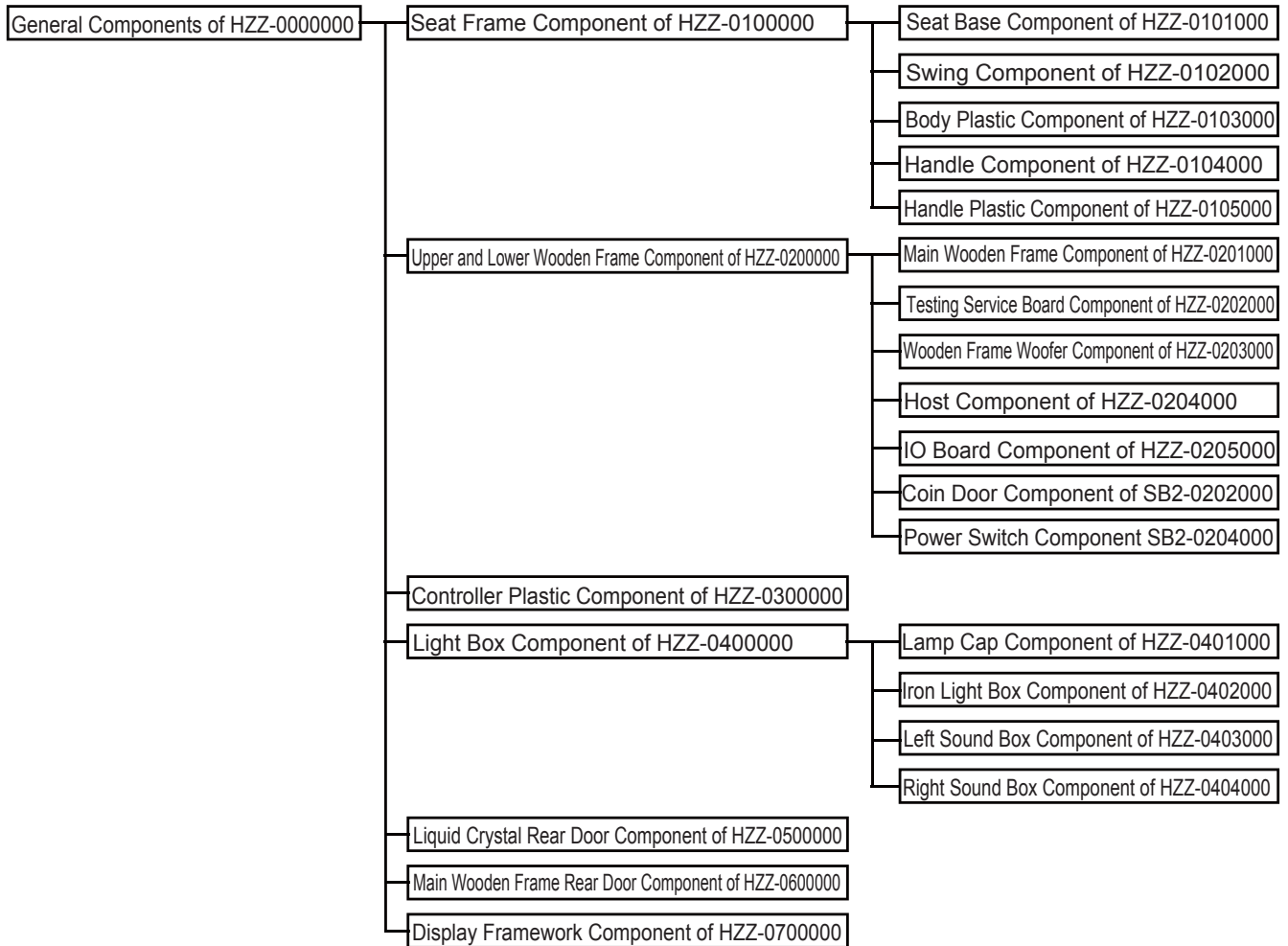

6.3 Seat Frame Component

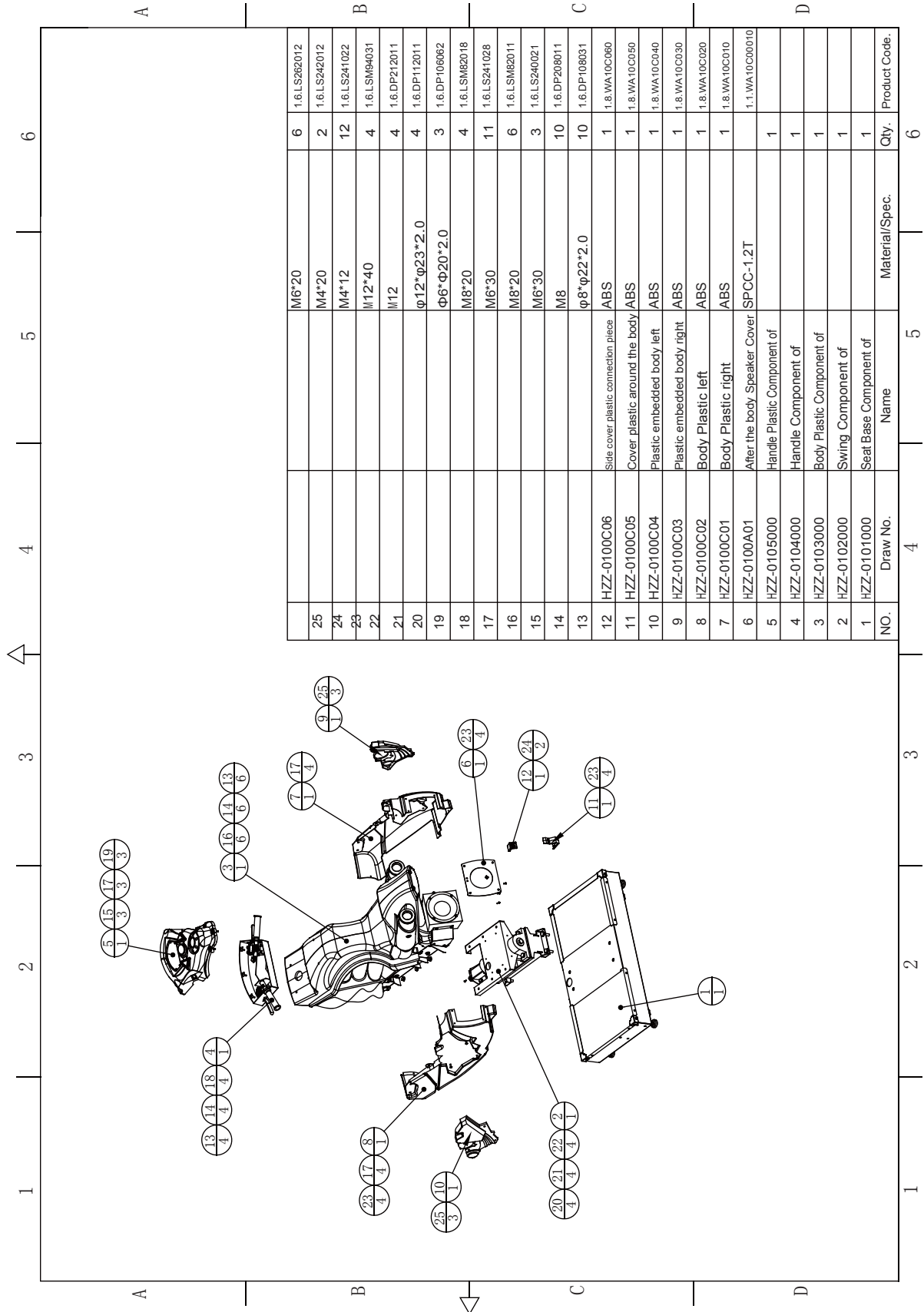

6.3 Seat Frame Component

6.3.1 Seat Base Component

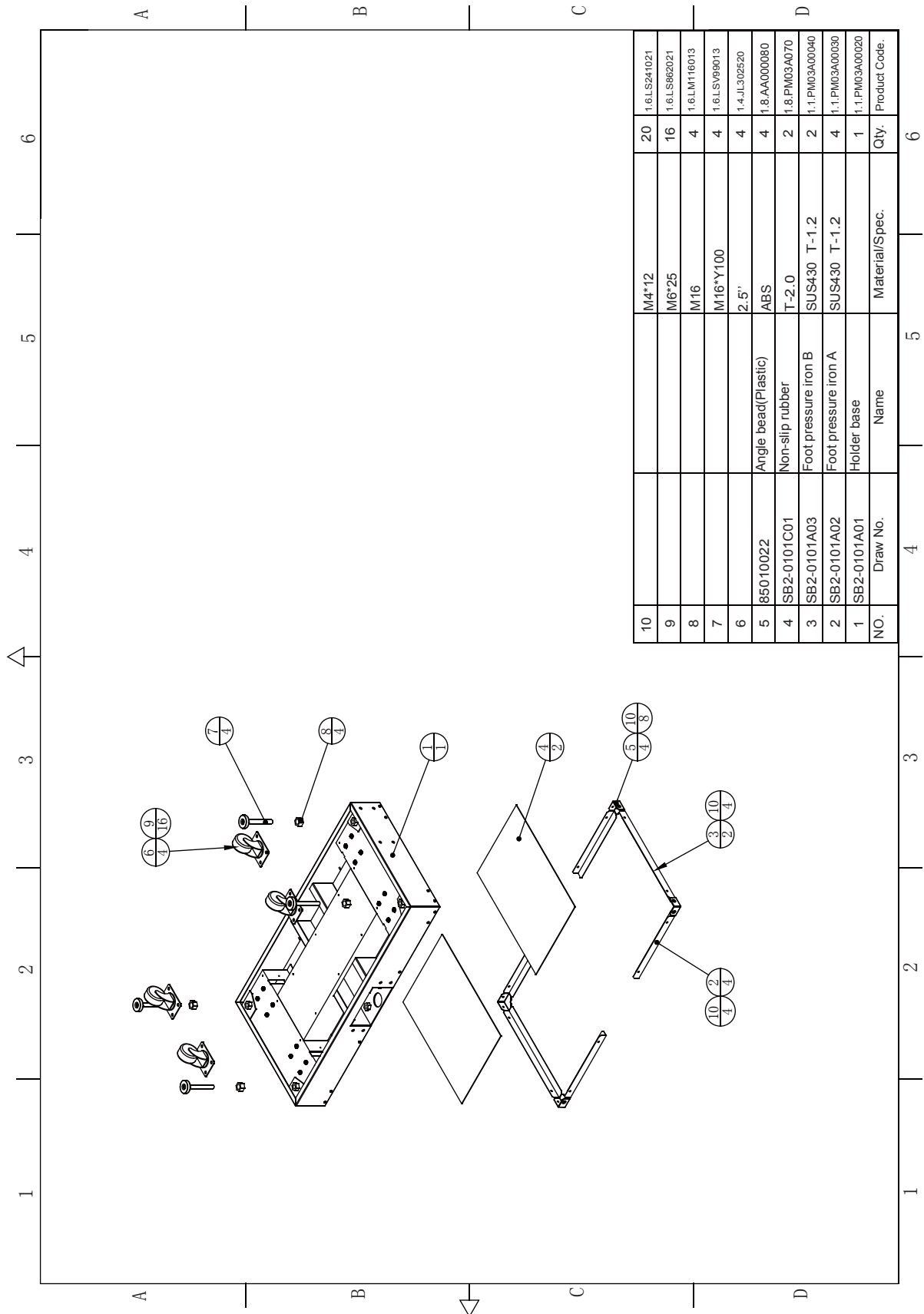

10		M4*12	20	1.6.L.S241021
9		M6*25	16	1.6.L.S862021
8		M16	4	1.6.L.M116013
7		M16*Y100	4	1.6.L.SV99013
6		2.5"	4	1.4.JL302520
5	85010022	Angle bead(Plastic)	4	1.8.AA000080
4	SB2-0101C01	Non-slip rubber	2	1.8.PM03A070
3	SB2-0101A03	Foot pressure iron B	2	1.1.PM03A00040
2	SB2-0101A02	Foot pressure iron A	4	1.1.PM03A00030
1	SB2-0101A01	Holder base	1	1.1.PM03A00020
NO.	Draw No.	Name	Qty.	Product Code.
	4	5	6	

6.3 Seat Frame Component

6.3.2 Swing Component

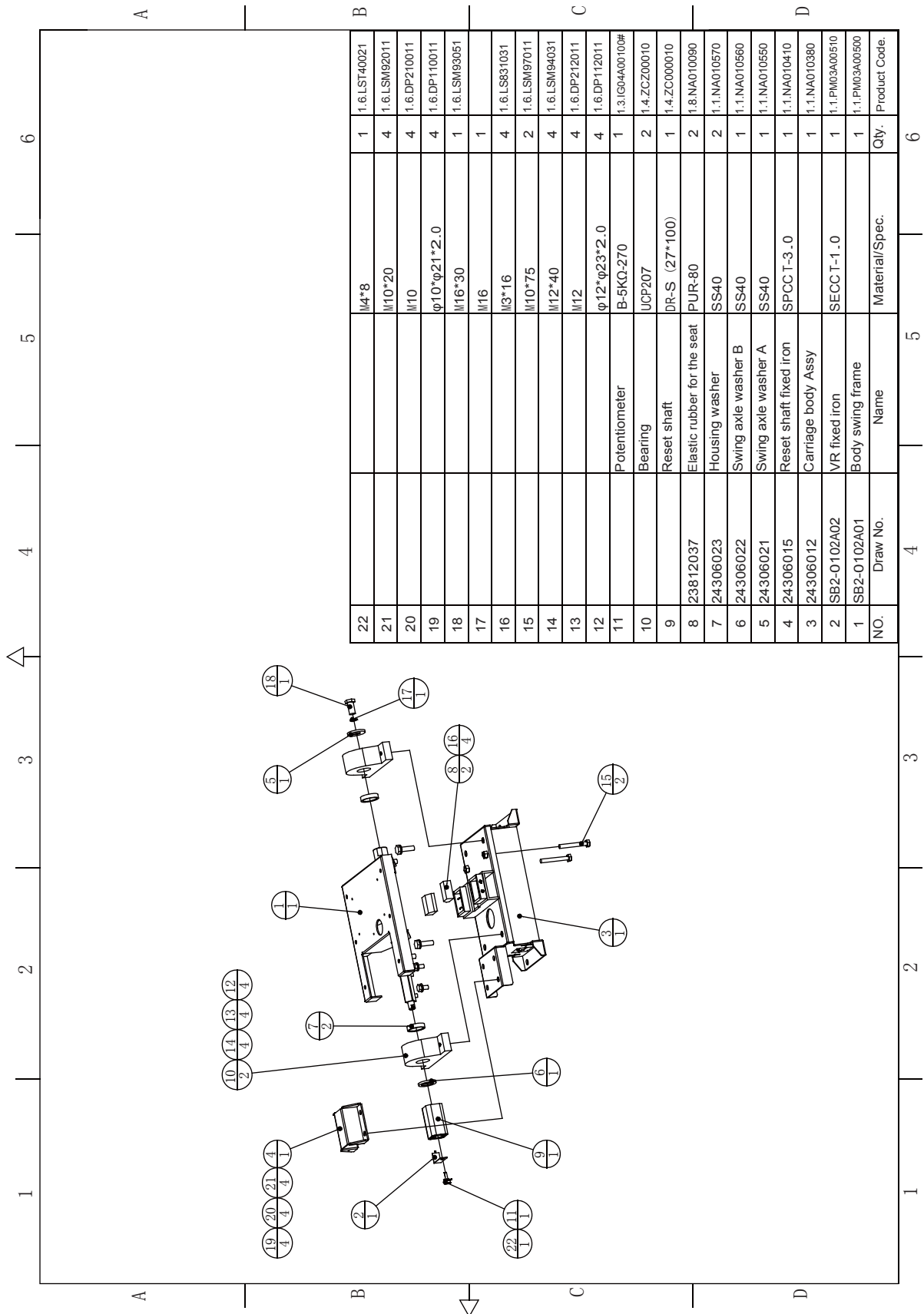

6.3 Seat Frame Component

6.3.3 Body Plastic Component

NO.	Draw No.	Name	Material/Spec.	Qty.	Product Code
27			M5	4	1.6.DP605010
26			M3*10	4	
25			M4*12	6	1.6.LS341021
24			M6*30	2	1.6.LS263011
23			M4	1	1.6.LM204013
22			M3*8	2	1.6.LS630021
21			M5*12	4	1.6.LS651021
20			M4*25	8	1.6.LS842021
19			M8	14	1.6.DP208011
18			φ8*φ22*2.0	14	1.6.DP108031
17			M8*20	14	1.6.LSM62011
16			M4*10	7	1.6.LS241028
15			M6*30	6	1.6.LS241028
14		Woofers	6.5 8Ω/80W/-150W	1	1.4.YS606020
13		Exhaust pipe LED board	WL_PCB1_0001_0029	2	1.4.IC901710
12		Rear LED board	WL_PCB2_0005_0016	1	1.4.IC901700
11	SNC-0400C01	SEAT	ABS	1	
10	SB2-0103A07	LED rear fixed iron	SPCCT-1.0	1	1.1.PM03A00110
9	SB2-0103D02	The exhaust pipe cover	PMMA	2	1.8.PM03A170
8	SB2-0103D01	Rear lamp cover plate	PMMA	1	1.8.PM03A180
7	SB2-0103A06	Exhaust pipe		2	1.1.PM03A00100
6	SB2-0103A03	Seat bracket R	SPCC	1	1.1.PM03A00070
5	SB2-0103A02	Seat bracket L	SPCC	1	1.1.PM03A00060
4					
3	HZZ-0103B01	Rear speakers	HDF-15.0T	1	1.2.WA10C00010
2	HZZ-0103A01	Rear speakers Fixed Iron R	SPCC-1.5T	1	1.1.WA10C00020
1	HZZ-0103A02	Rear speakers Fixed Iron L	SPCC-1.5T	1	1.1.WA10C00030

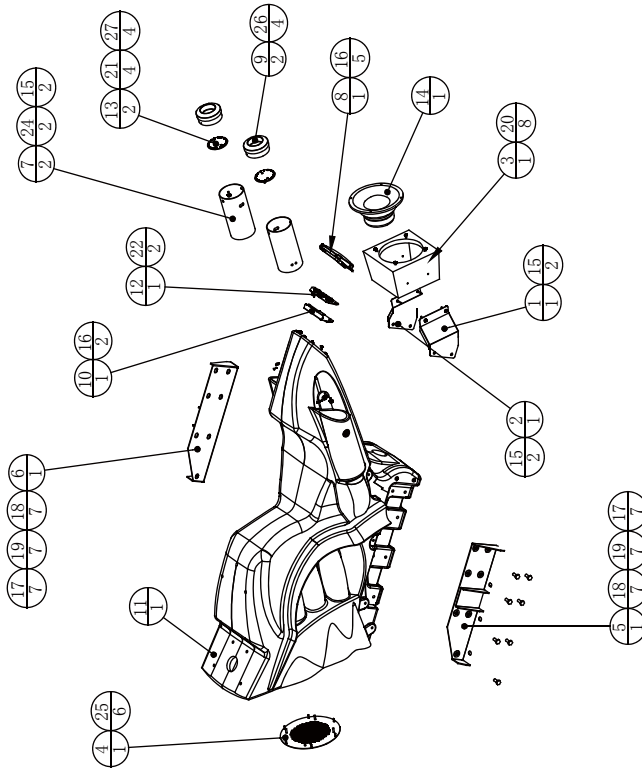

6.3 Seat Frame Component

6.3.4 Handle Component

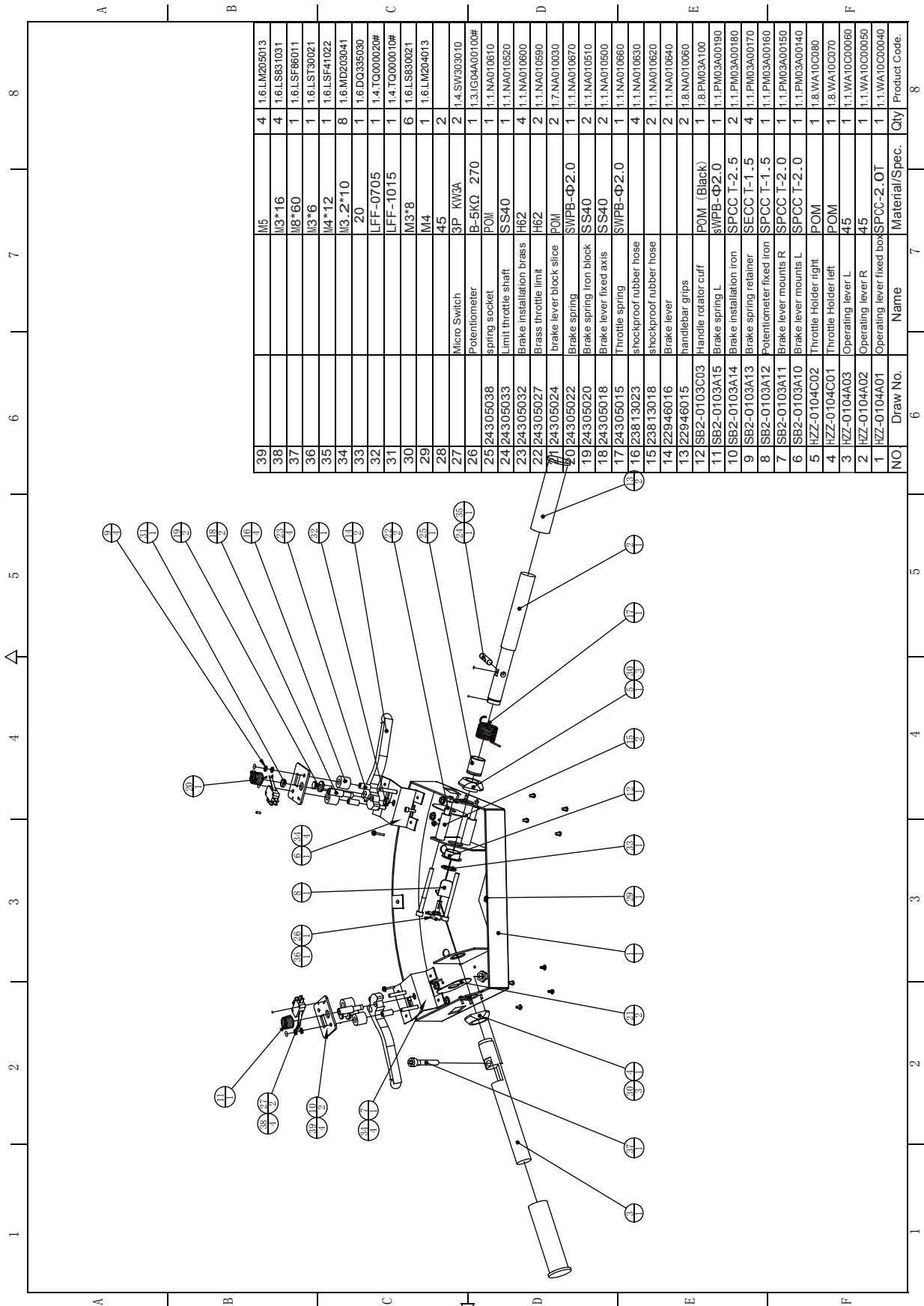

6.4 Upper and Lower Wooden Frame Component

The diagram shows an exploded view of the upper and lower wooden frame components. The parts are numbered 1 through 36. The upper frame (top half) includes panels (1-10), frames (11-14), and electrical components (15-18). The lower frame (bottom half) includes panels (19-28), frames (29-32), and electrical components (33-36). The diagram is divided into four vertical sections labeled A, B, C, and D.

NO.	Draw No.	Name	Material/Spec.	Qty.	Product Code
36		M3*16		3	1.6.LS331042
35		M4*16		6	1.6.LS341041
34		M8*50		2	1.6.LSM65011
33		M8*40		24	1.6.LSM64011
32		M8*30		8	1.6.LSM63011
31		M8		34	1.6.DF208011
30		Φ8*Φ22*2.0		34	1.6.DF108031
29		M4*30M4*30		2	1.6.LS243011
28		M5*30		8	1.6.LS253011
NO.	Draw No.	Name	Material/Spec.	Qty.	Product Code
27		M8		4	1.6.LM208013
26		M4*8		2	1.6.LS640021
25		M4*20		12	1.6.LS242011
24		M4*70		4	1.6.LS747012
23		M4		4	1.6.LM204013
22		M6		8	1.6.LM206013
21		M6*14/M6*25		8	1.6.LSM61020
20		JK-OP-03		1	1.4.GF100022
19		4.1-channel AMP		1	1.4.DY170020
18		Power supply		1	1.4.FS200041
17		Fan	120*120/AC220V	1	1.4.FS200041
16		Fan cover	120*120	2	1.4.FS300020
15		Plastic money box		1	1.8.AA000060
14	HZZ-0200B01	LCD fixed frame	HDF	1	1.2.WA10CC0020
13	SB2-0200A04	Wooden connection iron R	SPCC T-2.0	1	1.1.PM03A00230
12	SB2-0200A03	Wooden connection iron L	SPCC T-2.0	1	1.1.PM03A00220
11	SB2-0200A02	Moneybox	SPCC T-0.8	1	1.1.PM03A00210
10	HZZ-0200A03	console side Iron R	SPCC-1.0T	1	1.1.WA10CC0090
9	HZZ-0200A02	console side Iron L	SPCC-1.0T	1	1.1.WA10CC0080
8	SB2-0200A01	Wooden connection iron	SPCC-1.5T	1	1.1.WA10CC0070
7	HZZ-0205000	Frame seat connection	SPCC	1	
6	SB2-0204000	IO Board Component of		1	
5	SB2-0202000	Power Switch Component of		1	
4	HZZ-0204000	Coin Door Component of		1	
3	HZZ-0203000	Host Component of		1	
2	HZZ-0202000	Wooden Frame Wooter Component of		1	
1	HZZ-0201000	Testing Service Board Component of		1	
		Main Wooden Frame Component of		1	
		Name	Material/Spec.	Qty.	Product Code
				6	

6.4 Upper and Lower Wooden Frame Component

6.4.2 Testing Service Board Component

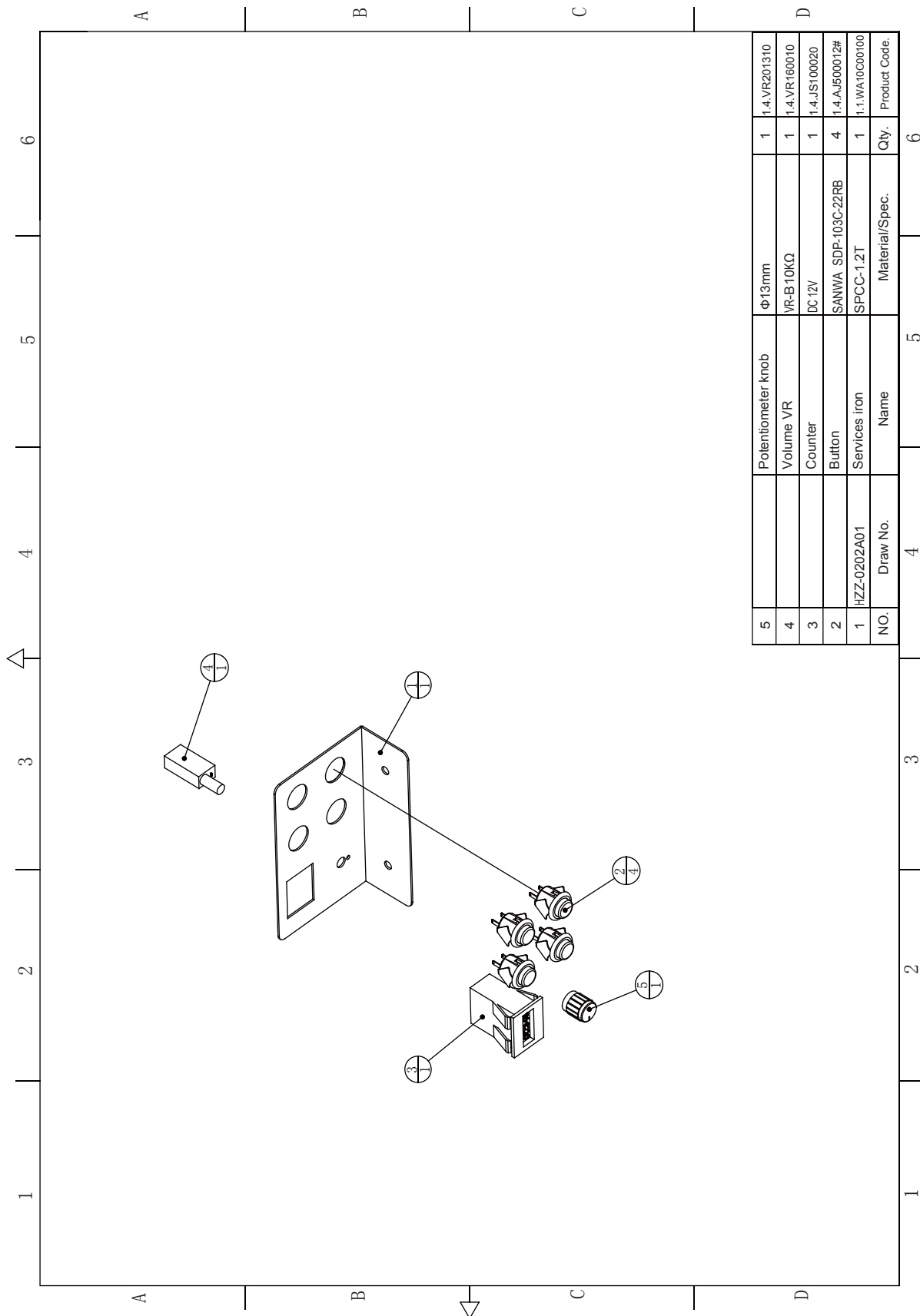

5	Potentiometer knob	φ13mm	1	1.4-VR201310
4	Volume VR	VR-B10KQ.	1	1.4-VR160010
3	Counter	DC 12V	1	1.4-JS100020
2	Button	SANWA SDP-103C-22RB	4	1.4-AJ500012#
1	Services iron	SPCC-1.2T	1	1.1-WA10C00100
NO.	Draw No.	Material/Spec.	Qty.	Product Code.
	4		6	

6.4 Upper and Lower Wooden Frame Component

6.4.3 Wooden Frame Woofer Component

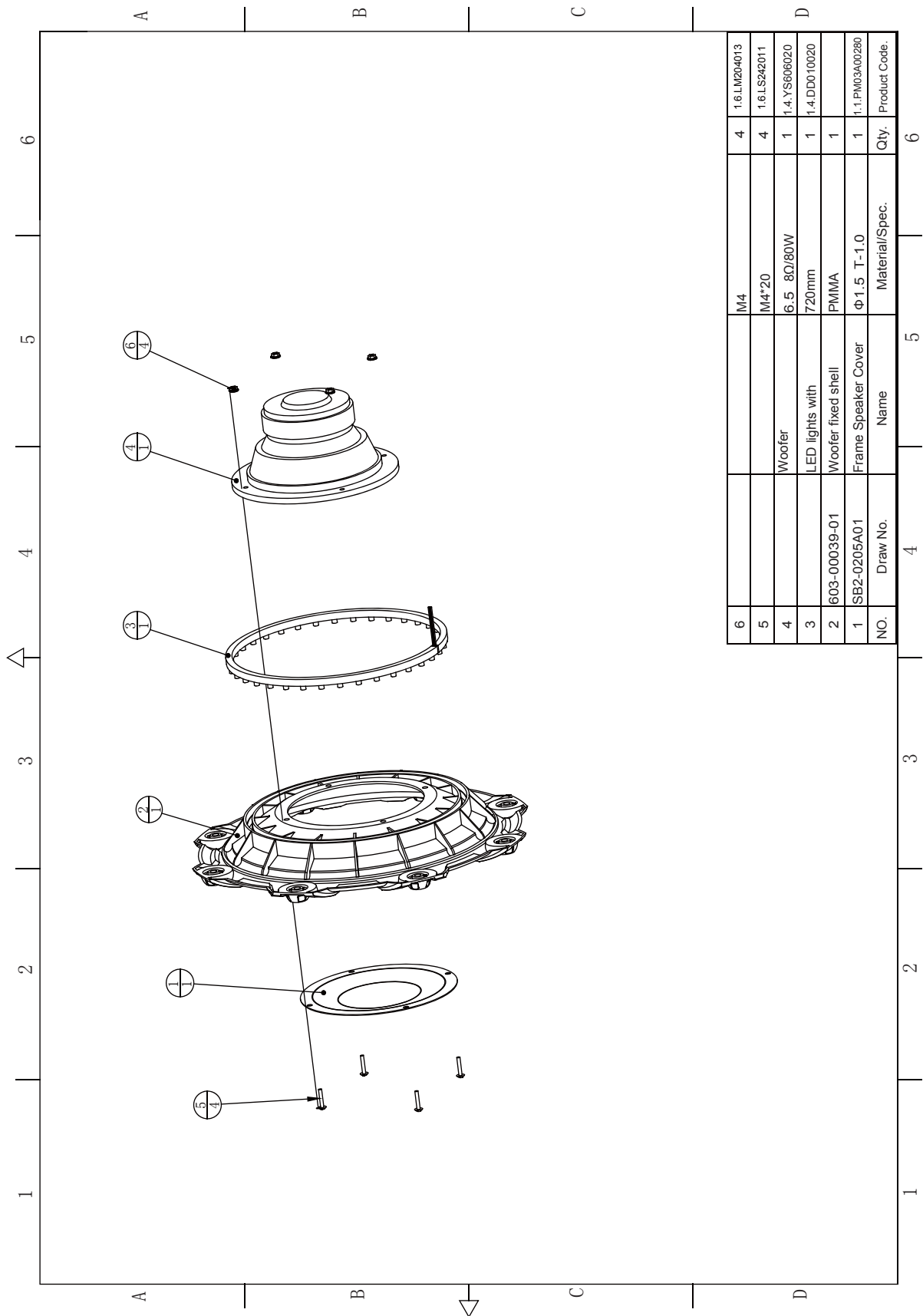

6	M4	4	1.6.LM204013
5	M4*20	4	1.6.LS242011
4	Woofer	1	1.4.YS606020
3	LED lights with	1	1.4.DD010020
2	603-00039-01	1	PMMA
1	SB2-0205A01	1	Φ1.5 T-1.0
NO.	Draw No.	Qty.	Product Code.
	Name	Material/Spec.	

6.4 Upper and Lower Wooden Frame Component

6.4.4 Host Component

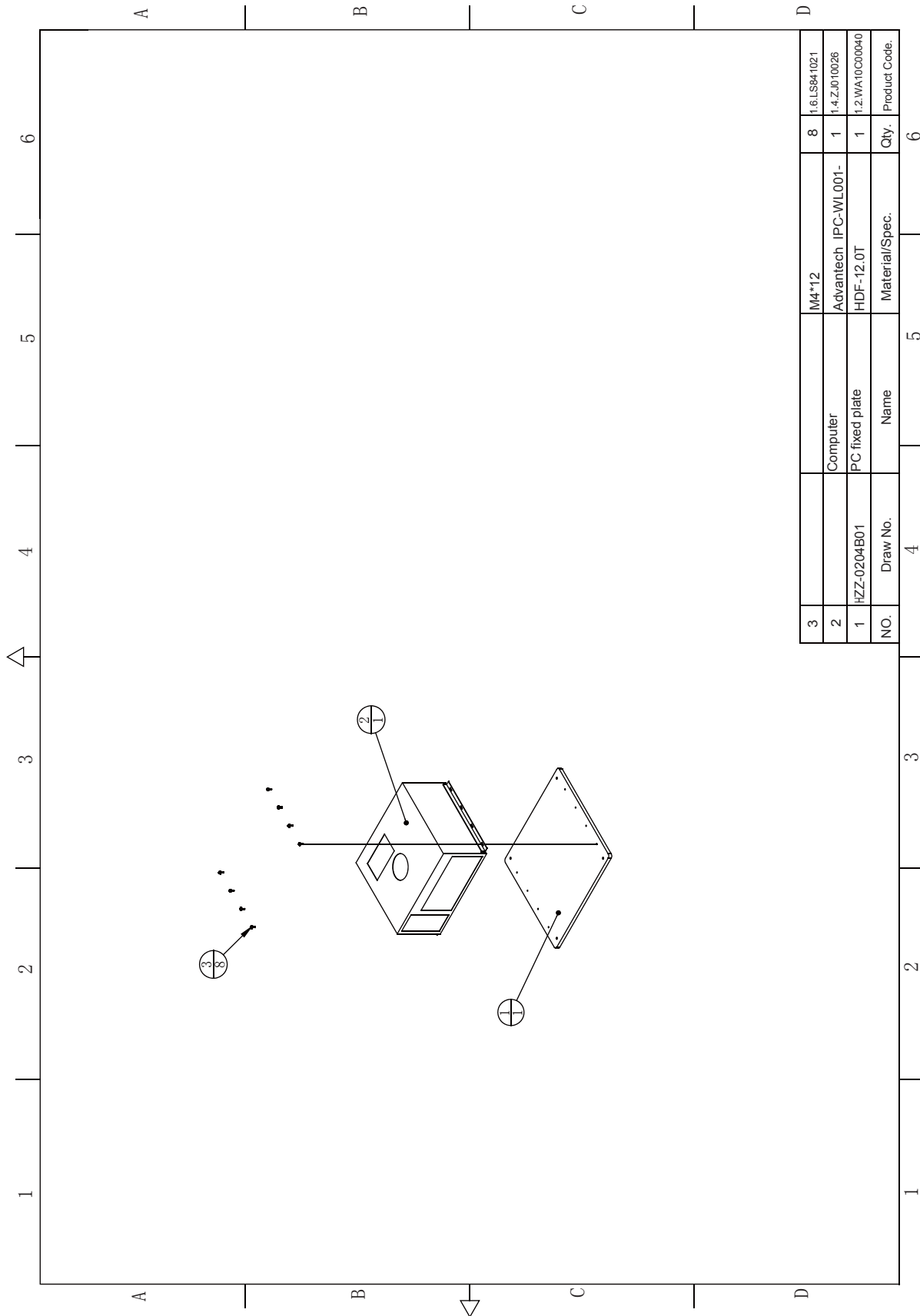

3		M4*12	8	1.6.LS841021
2	Computer	Advantech IPC-WL001-	1	1.4.ZJ010026
1	HZZ-0204B01	HDF-12.0T	1	1.2.WA10C00040
NO.	Draw No.	Name	Qty.	Product Code.
	4	5	6	

6.5 Controller Plastic Component

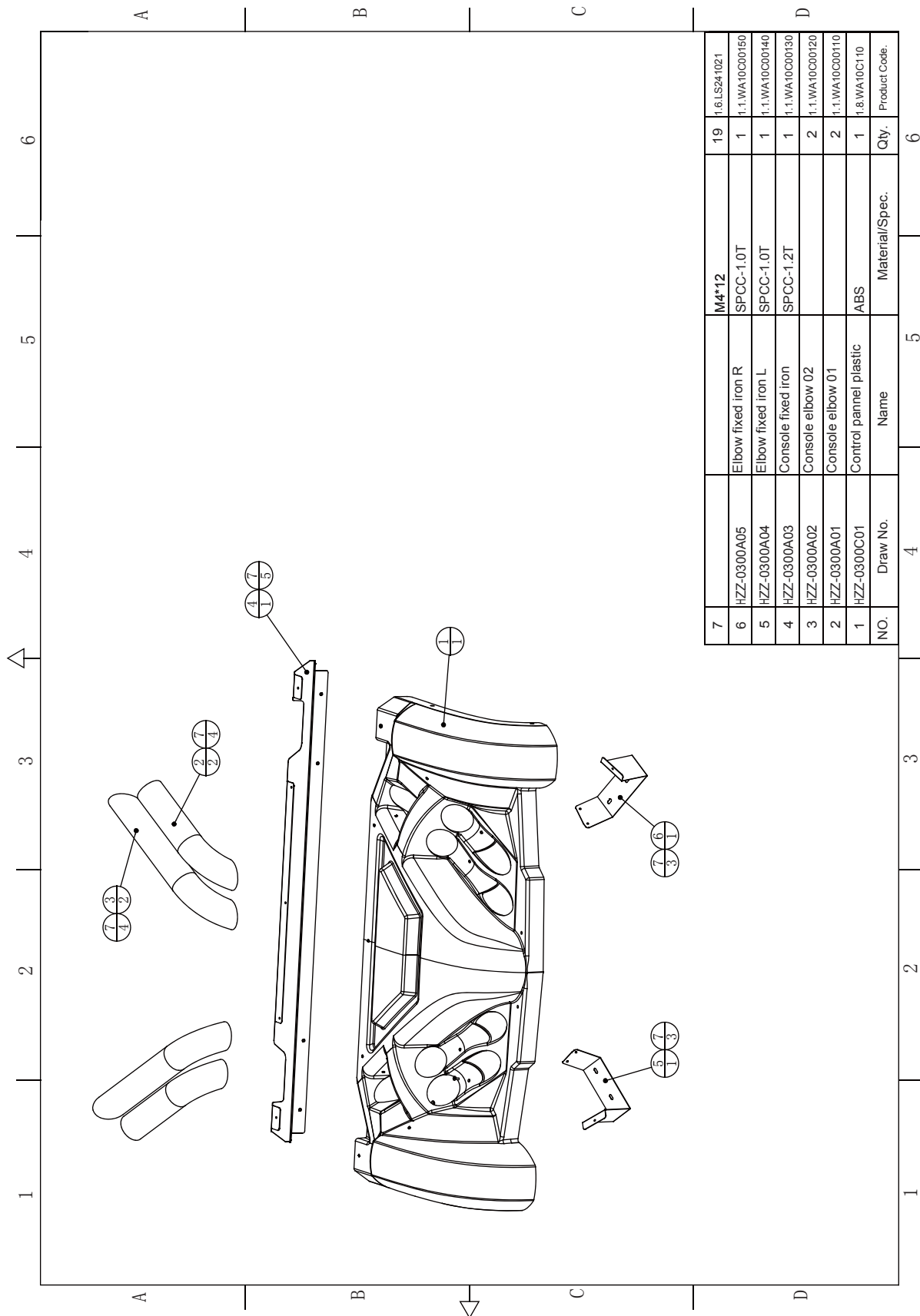

7		M4*12	19	1.6.LS241021
6	HZZ-0300A05	Elbow fixed iron R	1	1.1.WA10C00150
5	HZZ-0300A04	Elbow fixed iron L	1	1.1.WA10C00140
4	HZZ-0300A03	Console fixed iron	1	1.1.WA10C00130
3	HZZ-0300A02	Console elbow 02	2	1.1.WA10C00120
2	HZZ-0300A01	Console elbow 01	2	1.1.WA10C00110
1	HZZ-0300C01	Control pannel plastic	1	1.8.WA10C110
NO.	Draw No.	Name	Qty.	Product Code.
	4	5	6	

6.6 Light Box Component

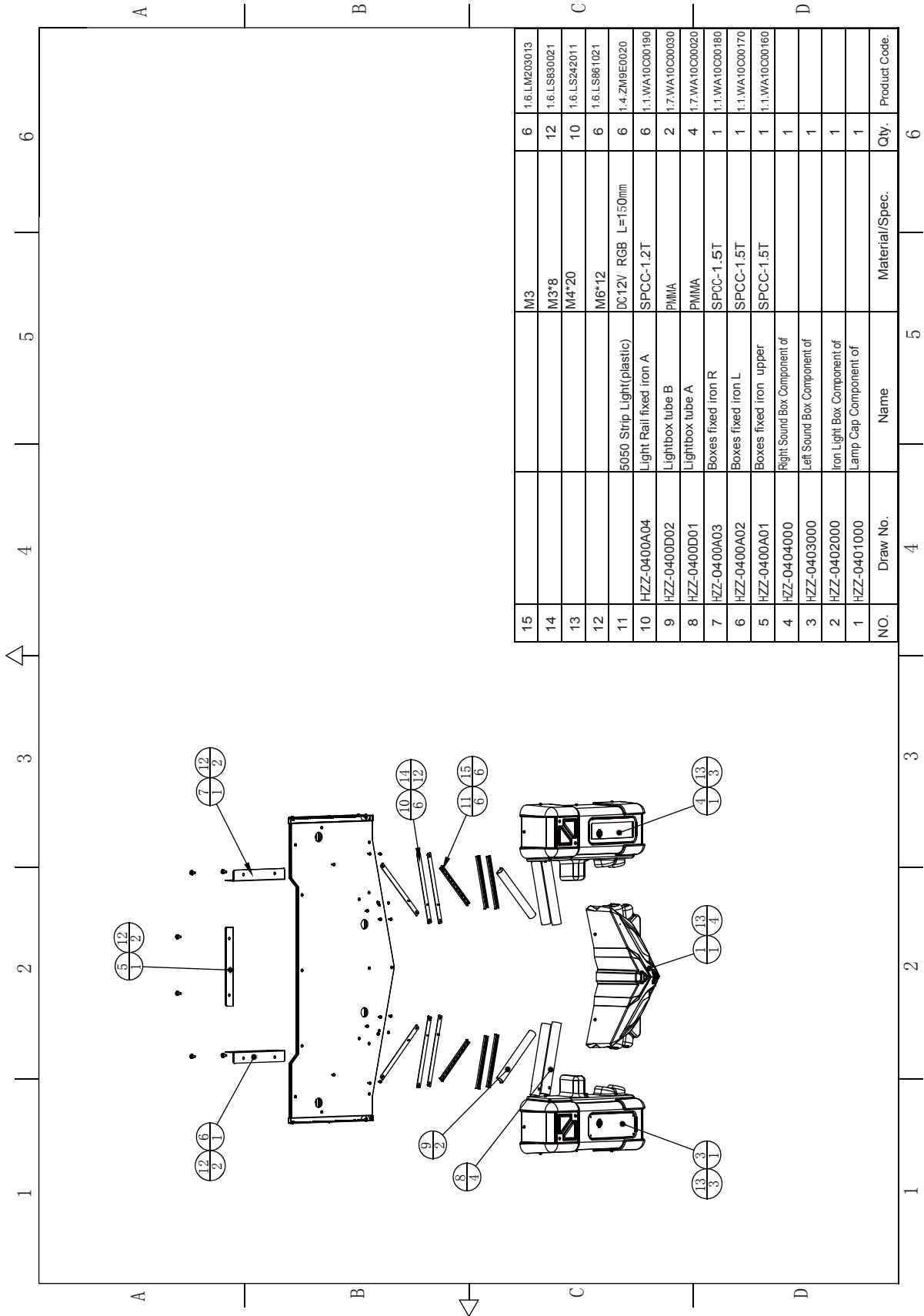

6.6 Light Box Component

6.6.1 Lamp Cap Component

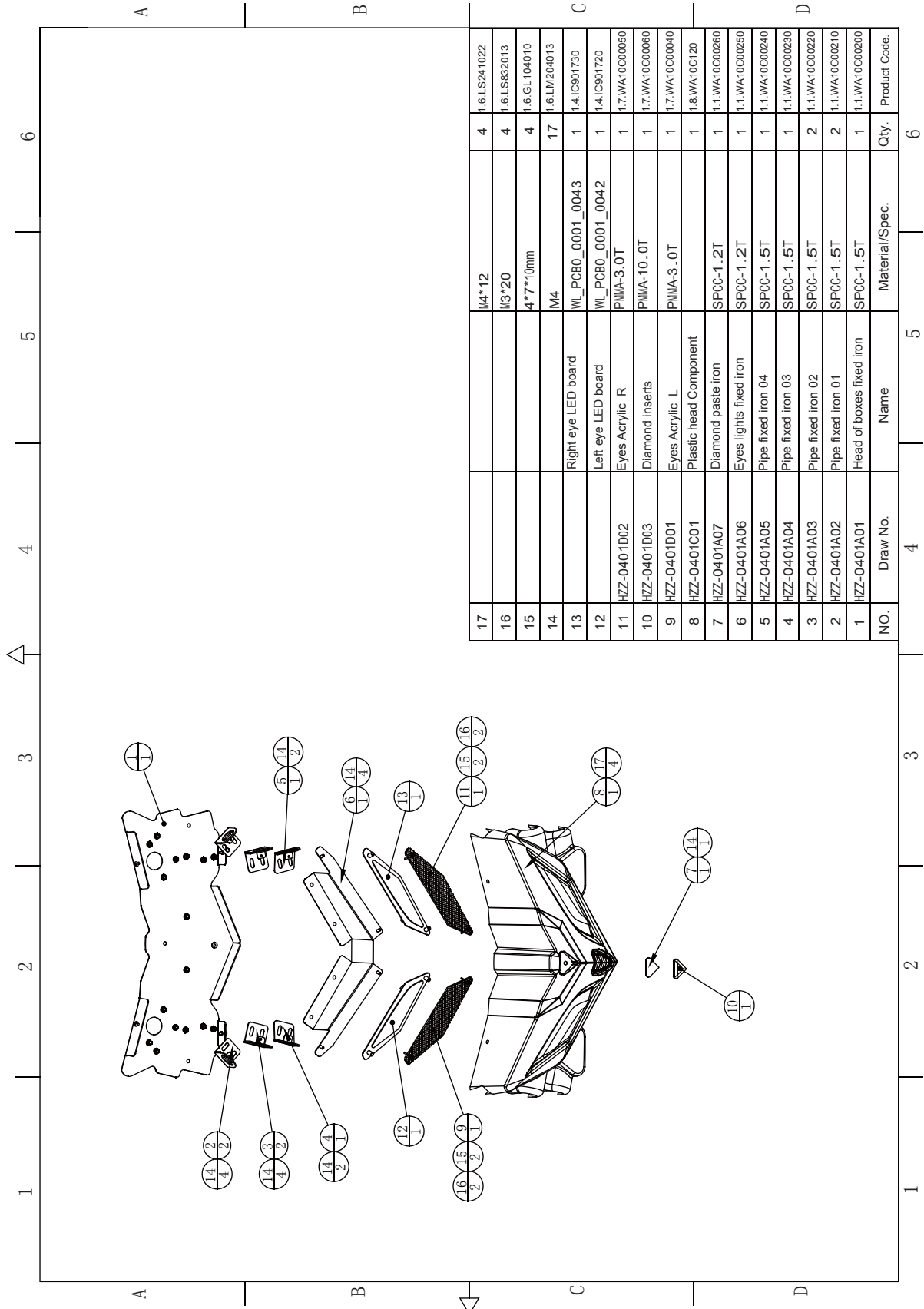

6.6 Light Box Component

6.6.2 Iron Light Box Component

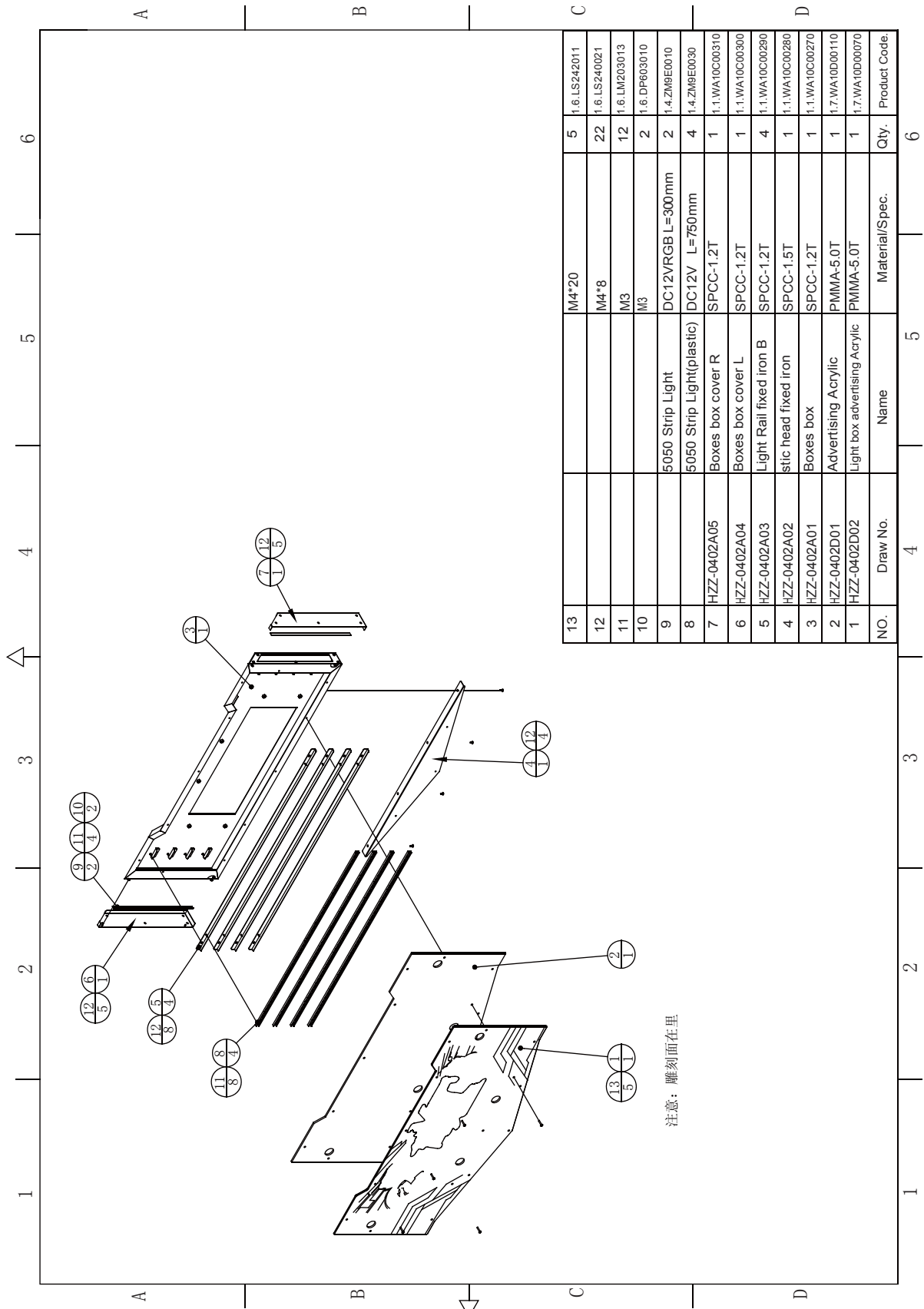

注意：雕刻面在里

6.8 Main Wooden Frame Rear Door Component

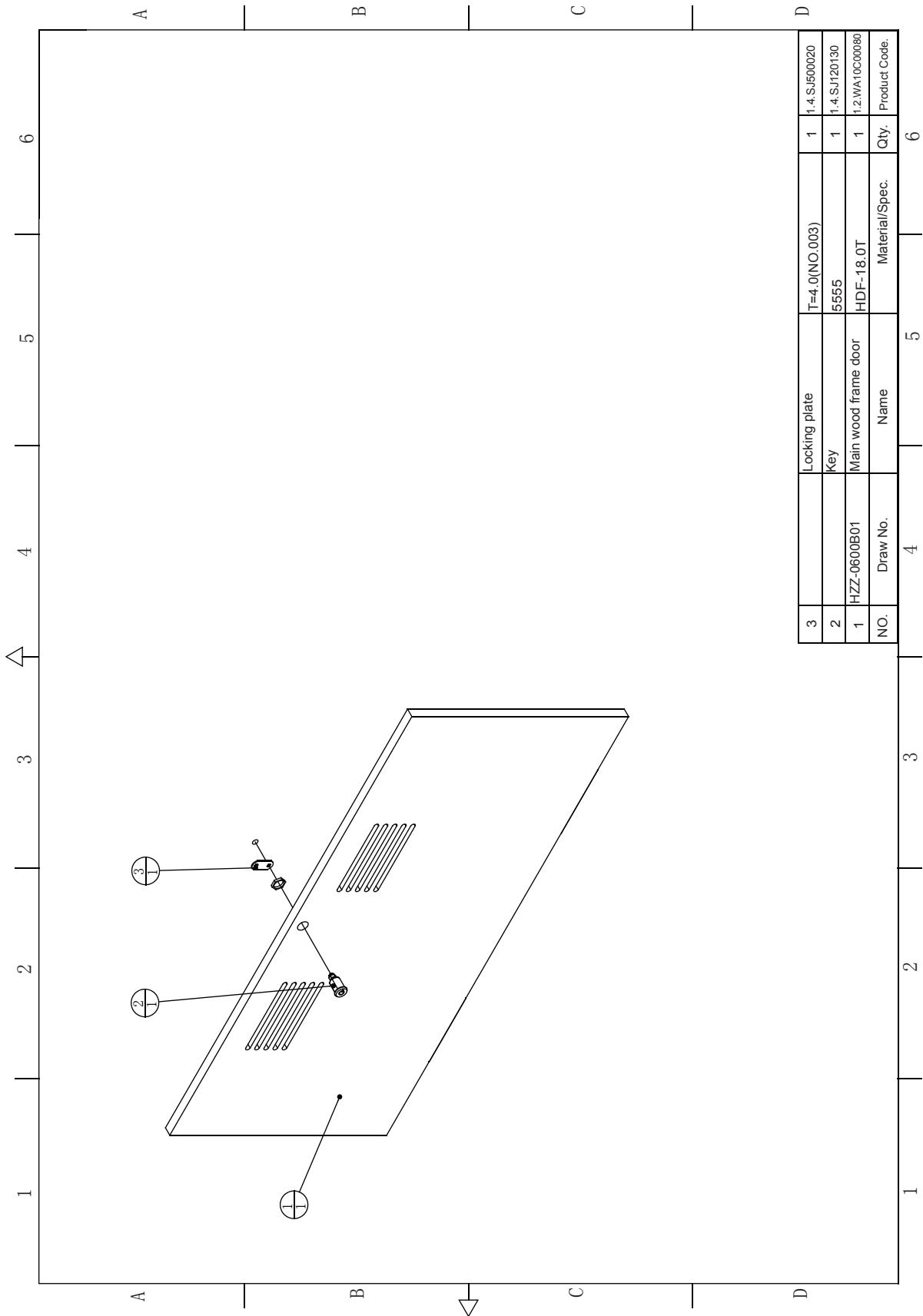

3	Locking plate	T=4.0(NO.003)	1	1.4.SJ500020
2	Key	5555	1	1.4.SJ120130
1	Main wood frame door	HDF-18.0T	1	1.2.WA10C00080
NO	Draw No.	Name	Material/Spec.	Qty.
	4	5	6	6

6.9 Display Framework Component

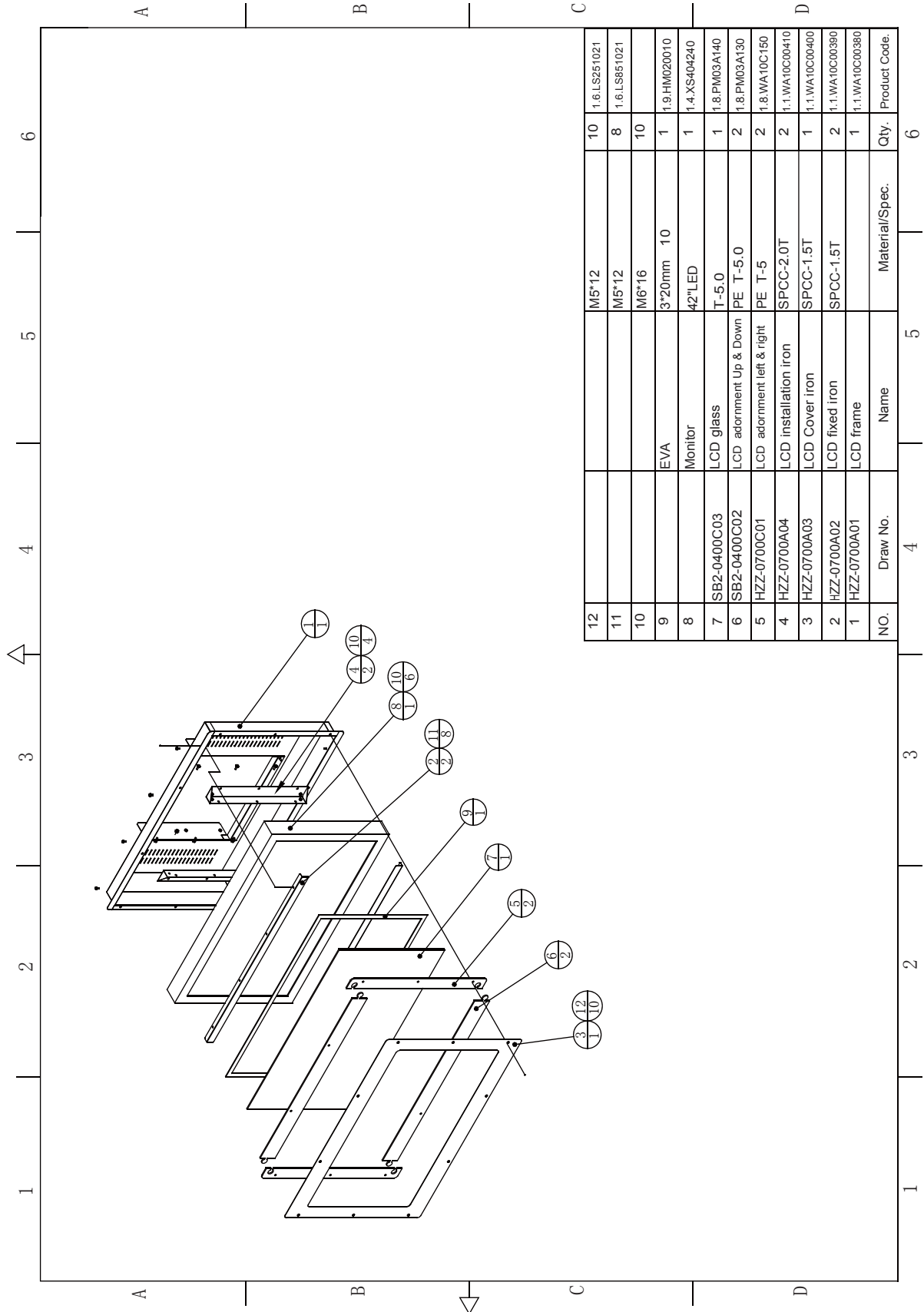

8. General Wiring Diagram

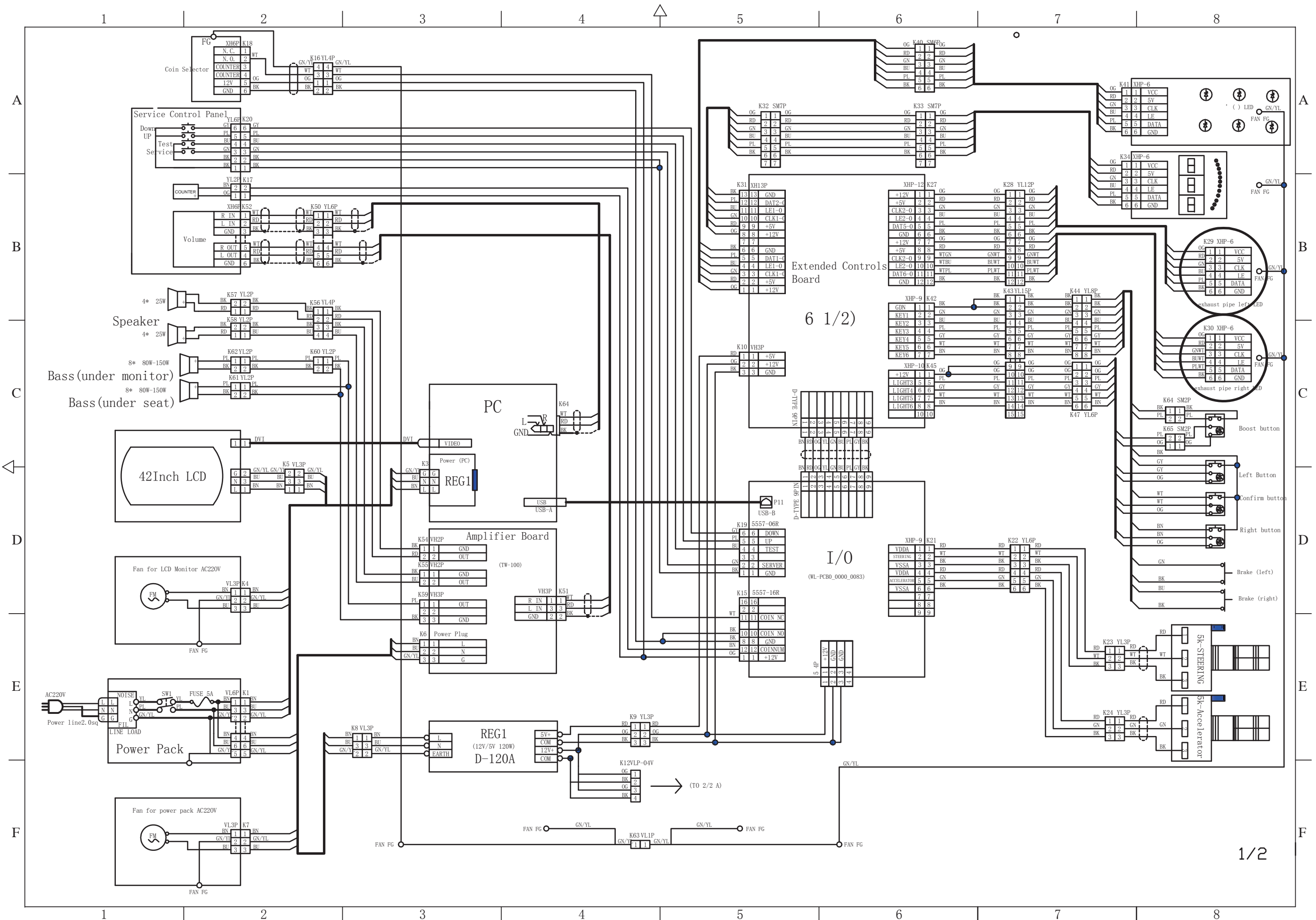

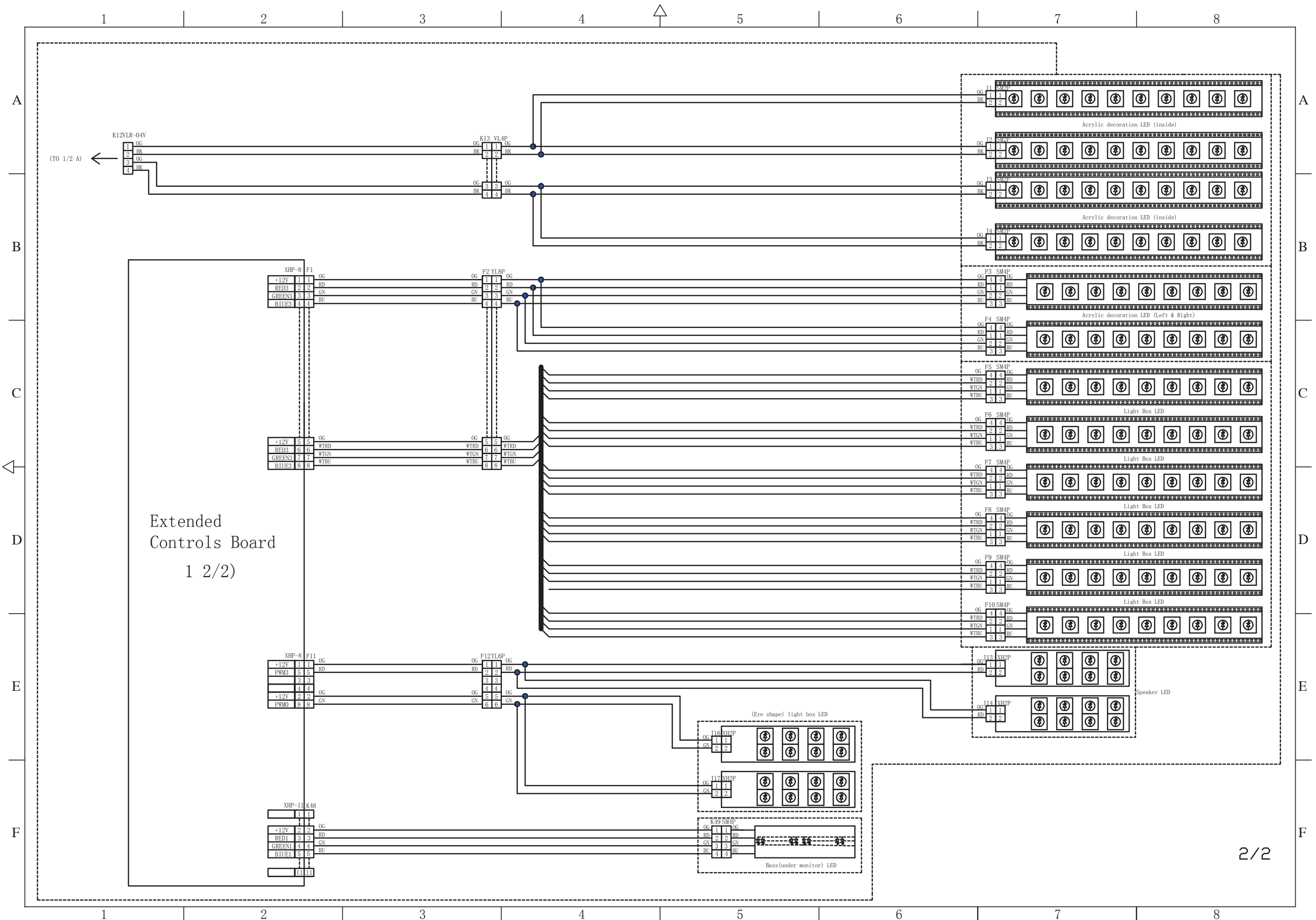

2/2

9. After-sales Service

Honorable customer !

Thank you for purchasing our product !

For your benefits, if you find any fault during the operation of the product, please use a technician who obtains a certificate related to mechanical engineering, electrical engineering or who engages in routine maintenance, repair and management of amusement machine to check the machine and inform us the fault in a timely manner. Our company will take corresponding measures to assist you to solve the problem promptly.

NOTICE: Do not dismount or replace any part of the machine without our technician's permission, or you will solely undertake the consequence !

Please pay attention to our contact information as follow:

Guangzhou Wahlap Technology Limited

Add: H1-H6 Startoon city, Yingxing Dong Road, Donghuan Street, Panyu, Guangzhou, China

Tel: +86 20 39226222 Fax: +86 20 39226300

Service Hotline: +86 20 39226222 4006-926-222

E-mail: sales@wahlap.com Postcode: 511490

<http://www.wahlap.com>



Ver.2.00

WAHLAP TECH

※ The specifications and operation instructions in this Manual are subject
to change without notice for reasons such as performance.
